

KC Rondelle isolante

Rondelle isolante avec capuchon intégré utilisée pour fixation d'ITE sur ossature bois et métallique.



Déscription de produit

Caractéristiques et avantages

- Recommandé pour la fixation d'ITE sur support bois avec vis UC et sur support métallique avec vis WB.
- Réduction de l'effet de pont thermique grâce à la conception spéciale du capuchon.
- Effort de maintien homogène.
- Installation rapide, simple et propre.
- Peut être utilisé avec une rosace d'appui KWL supplémentaire de diamètre 90, 110 ou 140 mm.

Applications

- Système d'isolation thermique par l'extérieur (ETICS)
- Panneaux de polystyrène expansé (PSE)
- Laine minérale
- Panneaux isolants à base de polystyrène

Supports

A utiliser dans:

- Tôle en acier et profilés métalliques
- Bois

Mise en œuvre

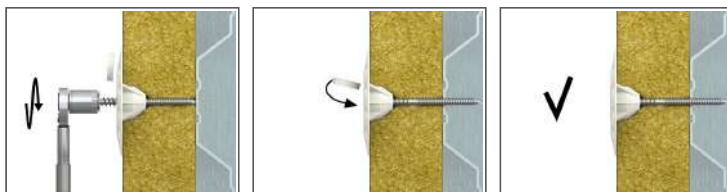

1. Insérer doucement la rondelle KC dans l'isolant.
2. Serrer une vis appropriée à la profondeur adéquate au travers de la rondelle et la couche d'isolant dans le support.
3. Pour les supports en bois il est recommandé d'installer la rondelle avec une vis durcie type UC.
4. Pour les supports en acier il est recommandé d'installer la rondelle avec une vis autoforeuse WB ou WX.

Déscription de produit

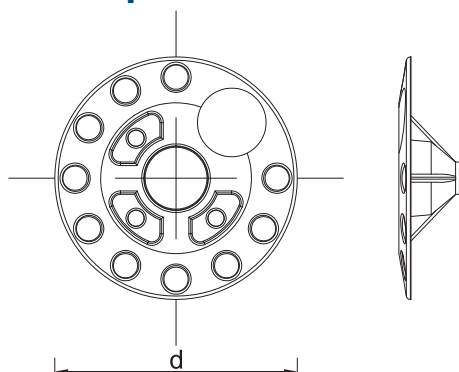

Dimension	Code produit	Cheville			Pièce à fixer
		Diamètre de la vis	Longueur	Diamtre de rosace	Epaisseur maxi
		d	L	D	t _{fix}
[mm]					
KC avec vis bois					
Ø5	KC + UC-5050	5	50	60	30
	KC + UC-5060	5	60	60	40
	KC + UC-5070	5	70	60	50
	KC + UC-5080	5	80	60	60
	KC + UC-5090	5	90	60	70
	KC + UC-50100	5	100	60	80
Ø6	KC + UC-60100	6	100	60	75
	KC + UC-60120	6	120	60	95
	KC + UC-60140	6	140	60	115
	KC + UC-60160	6	160	60	135
	KC + UC-60200	6	200	60	175
KC avec vis autoperceuse tle acier					
Ø5	KC + WB-48100	4.8	100	60	90
	KC + WB-48120	4.8	120	60	110
	KC + WB-48140	4.8	140	60	130
	KC + WB-48160	4.8	160	60	150
	KC + WB-48170	4.8	170	60	160
	KC + WB-48180	4.8	180	60	170
	KC + WB-48200	4.8	200	60	190
	KC + WB-48220	4.8	220	60	210

Spécifications techniques

Support			Bois		Tôle en acier
Profondeur hors-tout d'ancrage	h _{nom}	[mm]	20	25	0.75
Min. épaisseur de support	h _{min}	[mm]	20	25	0.75
Distance entre axes mini	s _{min}	[mm]	100	100	100
Distance au bord mini	c _{min}	[mm]	100	100	100
Diamtre de la cheville	d	[mm]	5	6	4.8

Données sur la performance de base

Données pour une seule fixation sans l'impact des bords et connecteurs voisins

Support		Bois	Bois	Tôle en acier
Profondeur d'ancrage effective h_{ef}	[mm]	20	25	0.75
CHARGES DE RUPTURE $N_{Ru,m}$				
KC + UC ø5	[kN]	0.78	-	-
KC + UC ø6	[kN]	-	0.98	-
KC + WB	[kN]	-	-	0.86
RÉSISTANCE CARACTÉRISTIQUE N_{Rk}				
KC + UC ø5	[kN]	0.73	-	-
KC + UC ø6	[kN]	-	0.91	-
KC + WB	[kN]	-	-	0.81
VALEUR DE CALCUL N_{Rd}				
KC + UC ø5	[kN]	0.36	-	-
KC + UC ø6	[kN]	-	0.45	-
KC + WB	[kN]	-	-	0.40
VALEUR RECOMMANDÉE N_{rec}				
KC + UC ø5	[kN]	0.26	-	-
KC + UC ø6	[kN]	-	0.32	-
KC + WB	[kN]	-	-	0.29
Cheville		KC		
Rigidité de la rosace	[kN/mm]	0.4		

Données logistiques

Dimension	Code produit	Cheville			Vis	Quantité [pcs]			Poids [kg]			Code barres
		Diamètre de la vis [mm]	Longueur [mm]	Diamètre de rosace [mm]		Boîte	Suremballage	Palette	Boîte	Suremballage	Palette	
ø5	KC + UC-5050	5	50	60								
	KC + UC-5060	5	60	60								
	KC + UC-5070	5	70	60								
	KC + UC-5080	5	80	60								
	KC + UC-5090	5	90	60								
	KC + UC-50100	5	100	60								
ø6	KC + UC-60100	6	100	60								
	KC + UC-60120	6	120	60								
	KC + UC-60140	6	140	60								
	KC + UC-60160	6	160	60								
	KC + UC-60200	6	200	60								
ø5	KC + WB-48100	4.8	100	60								
	KC + WB-48120	4.8	120	60								
	KC + WB-48140	4.8	140	60								
	KC + WB-48160	4.8	160	60								
	KC + WB-48170	4.8	170	60								
	KC + WB-48180	4.8	180	60								
	KC + WB-48200	4.8	200	60								
	KC + WB-48220	4.8	220	60								
ø4.8	R-WX-48T050				50	250	3000	72000	1.17	14.1	367.8	5906675104157
	R-WX-48T060				60	250	3000	72000	1.39	16.6	429.5	5906675104164
	R-WX-48T070				70	250	3000	72000	1.61	19.3	492.2	5906675104171
	R-WX-48T080				80	250	3000	72000	1.86	22.3	564.8	5906675104188
	R-WX-48T100				100	200	2400	57600	1.86	22.4	566.8	5906675104201
	R-WX-48T120				120	200	2400	57600	2.2	26.9	675.4	5906675104232
	R-WX-48T140				140	200	2400	57600	2.6	31.3	780.2	5906675104256

Données logistiques

Dimension	Code produit	Cheville			Vis Longueur [mm]	Quantité [pcs]			Poids [kg]			Code barres
		Diamètre de la vis [mm]	Longueur [mm]	Diamtre de rosace [mm]		Boîte	Suremballage	Palette	Boîte	Suremballage	Palette	
Ø4.8	R-WX-48T160				160	100	1200	28800	1.51	18.1	463.7	5906675104263
	R-WX-48T180				180	100	100	16800	1.75	1.75	324.7	5906675104270
	R-WX-48T200				200	100	100	16800	1.93	1.93	353.6	5906675104287
	R-WX-48T240				240	100	100	16800	2.3	2.3	408.8	5906675104300
	R-WX-48T300				300	100	100	16800	2.8	2.8	498.0	5906675104317
	R-WO-48T060				60	250	3000	72000	1.38	16.6	428.6	5906675104676
	R-WO-48T080				80	250	3000	72000	1.81	21.7	551.6	5906675104683
	R-WO-48T100				100	200	3200	76800	1.85	29.6	741.2	5906675104690
	R-WO-48T120				120	200	3200	76800	2.1	33.9	842.9	5906675104706
	R-WO-48T140				140	200	2400	57600	2.5	30.4	760.4	5906675104713
	R-WO-48T160				160	100	1200	28800	1.59	19.1	488.2	5906675104720
	R-WO-48T180				180	100	100	16800	1.83	1.83	337.8	5906675104744
	R-WO-48T200				200	100	100	16800	2.0	2.0	371.5	5906675104751
	R-WO-48T240				240	100	100	16800	2.2	2.2	399.9	5906675104768
	R-WO-48T300				300	100	100	16800	2.7	2.7	485.8	5906675104775
Ø6.1	R-WBT-61050				50	100	3200	76800	0.79	25.2	634.4	5906675101200
	R-WBT-61075				75	100	1600	38400	1.11	17.7	454.3	5906675101231
	R-WBT-61090				90	100	1600	38400	1.34	21.4	543.8	5906675101309
	R-WBT-61100				100	100	1600	38400	1.49	23.9	602.5	5906675101408
	R-WBT-61120				120	100	1200	28800	1.77	21.3	540.9	5906675101439
	R-WBT-61140				140	100	1200	28800	2.0	24.5	618.7	5906675101460
	R-WBT-61160				160	100	1200	28800	2.3	28.1	704.2	5906675101514
	R-WBT-61180				180	100	100	16800	2.7	2.7	477.9	5906675225173
	R-WBT-61200				200	100	100	16800	2.9	2.9	518.5	5906675101927
	R-WBT-61220				220	100	100	16800	3.2	3.2	568.4	5906675102214
	R-WBT-61240				240	100	100	16800	3.5	3.5	620.7	5906675102245
	R-WBT-61260				260	100	100	16800	3.8	3.8	661.7	5906675102269
	R-WBT-61300				300	100	100	7800	4.3	4.3	367.0	5906675102290

TRADUCTION FRANCAISE LIBRE
ADAM MATERIAUX

KC Isolerende ring

Isolerende ring met geïntegreerde kap gebruikt voor IHO-bevestiging op houten en metalen frame.



Productbeschrijving

Kenmerken en voordelen:

- Aanbevolen voor bevestiging van ITE op een houten steun met UC-schroeven en op een metalen steun met WB-schroeven.
- Vermindering van het koudebruggeffect dankzij het speciale ontwerp van de dop.
- Homogene onderhoudsinspanning.
- Snelle, eenvoudige en schone installatie.
- Te gebruiken met een steunrozet Extra KWL met een diameter van 90, 110 of 140 mm.

Toepassingen

- Thermisch isolatiesysteem van buitenaf (ETICS)
- Panelen van geëxpandeerd polystyreen (EPS)
- Minerale wol
- Isolerende panelen op basis van polystyreen

Ondersteunt

A utiliser dans:

- Staalplaat en metalen profielen
- Drankje

Implementatie

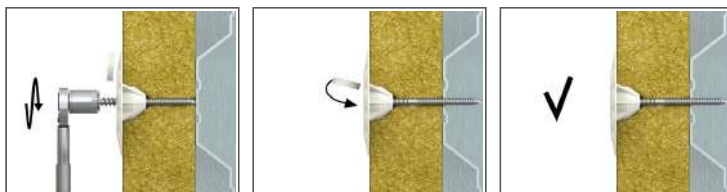

1. Steek de KC-ring voorzichtig in de isolatie.
2. Draai een geschikte schroef tot de juiste diepte door de ring en de isolatielaag in de beugel.
3. Voor houten steunen wordt aanbevolen om de ring te installeren met een geharde schroef van het type UC.
4. Voor stalen steunen wordt aanbevolen om de ring te installeren met een WB of WX zelftappende schroef.

Productomschrijving

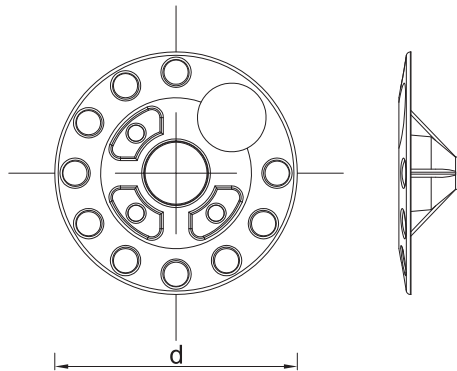

Afmetingen	Productcode	Pin			Onderdeel nog te repareren
		Schroef diameter	Lengte	Diameter rozet	Maximale dikte
		d	L	D	t _{fix}
[mm]					
KC met houtschroeven					
Ø5	KC + UC-5050	5	50	60	30
	KC + UC-5060	5	60	60	40
	KC + UC-5070	5	70	60	50
	KC + UC-5080	5	80	60	60
	KC + UC-5090	5	90	60	70
	KC + UC-50100	5	100	60	80
Ø6	KC + UC-60100	6	100	60	75
	KC + UC-60120	6	120	60	95
	KC + UC-60140	6	140	60	115
	KC + UC-60160	6	160	60	135
	KC + UC-60200	6	200	60	175
KC met zelfborende staalplaat Schroef					
Ø5	KC + WB-48100	4.8	100	60	90
	KC + WB-48120	4.8	120	60	110
	KC + WB-48140	4.8	140	60	130
	KC + WB-48160	4.8	160	60	150
	KC + WB-48170	4.8	170	60	160
	KC + WB-48180	4.8	180	60	170
	KC + WB-48200	4.8	200	60	190
	KC + WB-48220	4.8	220	60	210

Technische specificaties

Steun			Hout		Staalplaat
	h _{nom}	[mm]	20	25	0.75
Totale verankeringsdiepte	h _{nom}	[mm]	20	25	0.75
Min. laagdikte:	h _{min}	[mm]	20	25	0.75
Minimale afstand tussen assen	s _{min}	[mm]	100	100	100
Minimale randafstand	c _{min}	[mm]	100	100	100
Enkeldiameter	d	[mm]	5	6	4.8

Prestatiegegevens basislijn

Gegevens voor een enkele bevestiging zonder de impact van aangrenzende randen en connectoren

Ondersteuning		Bois	Bois	Tôle en acier
Effectieve verankeringsdiepte h_{ef}	[mm]	20	25	0.75
BREEKLADEN $N_{Ru,m}$				
KC + UC ø5	[kN]	0.78	-	-
KC + UC ø6	[kN]	-	0.98	-
KC + WB	[kN]	-	-	0.86
KENMERKENDE WEERSTAND N_{Rk}				
KC + UC ø5	[kN]	0.73	-	-
KC + UC ø6	[kN]	-	0.91	-
KC + WB	[kN]	-	-	0.81
BEREKENINGSWAARDE N_{Rd}				
KC + UC ø5	[kN]	0.36	-	-
KC + UC ø6	[kN]	-	0.45	-
KC + WB	[kN]	-	-	0.40
AANBEVOLEN WAARDE N_{rec}				
KC + UC ø5	[kN]	0.26	-	-
KC + UC ø6	[kN]	-	0.32	-
KC + WB	[kN]	-	-	0.29
Pin		KC		
Stijfheid van de rozet	[kN/mm]	0.4		

Logistieke gegevens

Afmetingen	Productcode	Pin			Schroef	Hoeveelheid [st]			Gewicht (kg)			Streepjescode
		Schroef diameter [mm]	Lengte [mm]	Diameter rozet [mm]	Lengte [mm]	Doos	Verpakking	Palet	Doos	Verpakking	Palet	
ø5	KC + UC-5050	5	50	60								
	KC + UC-5060	5	60	60								
	KC + UC-5070	5	70	60								
	KC + UC-5080	5	80	60								
	KC + UC-5090	5	90	60								
	KC + UC-50100	5	100	60								
ø6	KC + UC-60100	6	100	60								
	KC + UC-60120	6	120	60								
	KC + UC-60140	6	140	60								
	KC + UC-60160	6	160	60								
	KC + UC-60200	6	200	60								
ø5	KC + WB-48100	4.8	100	60								
	KC + WB-48120	4.8	120	60								
	KC + WB-48140	4.8	140	60								
	KC + WB-48160	4.8	160	60								
	KC + WB-48170	4.8	170	60								
	KC + WB-48180	4.8	180	60								
	KC + WB-48200	4.8	200	60								
	KC + WB-48220	4.8	220	60								
ø4.8	R-WX-48T050				50	250	3000	72000	1.17	14.1	367.8	5906675104157
	R-WX-48T060				60	250	3000	72000	1.39	16.6	429.5	5906675104164
	R-WX-48T070				70	250	3000	72000	1.61	19.3	492.2	5906675104171
	R-WX-48T080				80	250	3000	72000	1.86	22.3	564.8	5906675104188
	R-WX-48T100				100	200	2400	57600	1.86	22.4	566.8	5906675104201
	R-WX-48T120				120	200	2400	57600	2.2	26.9	675.4	5906675104232
	R-WX-48T140				140	200	2400	57600	2.6	31.3	780.2	5906675104256

Logistieke gegevens

Afmetingen	Productcode	Pin			Schroef	Hoeveelheid [st]			Gewicht (kg)			Streepjescode
		Schroef diameter [mm]	Lengte [mm]	Diameter rozet [mm]	Lengte [mm]	Doos	Verpakking	Palet	Doos	Verpakking	Palet	
Ø4.8	R-WX-48T160				160	100	1200	28800	1.51	18.1	463.7	5906675104263
	R-WX-48T180				180	100	100	16800	1.75	1.75	324.7	5906675104270
	R-WX-48T200				200	100	100	16800	1.93	1.93	353.6	5906675104287
	R-WX-48T240				240	100	100	16800	2.3	2.3	408.8	5906675104300
	R-WX-48T300				300	100	100	16800	2.8	2.8	498.0	5906675104317
	R-WO-48T060				60	250	3000	72000	1.38	16.6	428.6	5906675104676
	R-WO-48T080				80	250	3000	72000	1.81	21.7	551.6	5906675104683
	R-WO-48T100				100	200	3200	76800	1.85	29.6	741.2	5906675104690
	R-WO-48T120				120	200	3200	76800	2.1	33.9	842.9	5906675104706
	R-WO-48T140				140	200	2400	57600	2.5	30.4	760.4	5906675104713
	R-WO-48T160				160	100	1200	28800	1.59	19.1	488.2	5906675104720
	R-WO-48T180				180	100	100	16800	1.83	1.83	337.8	5906675104744
	R-WO-48T200				200	100	100	16800	2.0	2.0	371.5	5906675104751
	R-WO-48T240				240	100	100	16800	2.2	2.2	399.9	5906675104768
	R-WO-48T300				300	100	100	16800	2.7	2.7	485.8	5906675104775
Ø6.1	R-WBT-61050				50	100	3200	76800	0.79	25.2	634.4	5906675101200
	R-WBT-61075				75	100	1600	38400	1.11	17.7	454.3	5906675101231
	R-WBT-61090				90	100	1600	38400	1.34	21.4	543.8	5906675101309
	R-WBT-61100				100	100	1600	38400	1.49	23.9	602.5	5906675101408
	R-WBT-61120				120	100	1200	28800	1.77	21.3	540.9	5906675101439
	R-WBT-61140				140	100	1200	28800	2.0	24.5	618.7	5906675101460
	R-WBT-61160				160	100	1200	28800	2.3	28.1	704.2	5906675101514
	R-WBT-61180				180	100	100	16800	2.7	2.7	477.9	5906675225173
	R-WBT-61200				200	100	100	16800	2.9	2.9	518.5	5906675101927
	R-WBT-61220				220	100	100	16800	3.2	3.2	568.4	5906675102214
	R-WBT-61240				240	100	100	16800	3.5	3.5	620.7	5906675102245
	R-WBT-61260				260	100	100	16800	3.8	3.8	661.7	5906675102269
	R-WBT-61300				300	100	100	7800	4.3	4.3	367.0	5906675102290

VRIJ NEDERLANDSE VERTALING
ADAM MATERIAUX

KC Isolierscheibe

Isolierscheibe mit integrierter Kappe zur Befestigung von ITE an Holz- und Metallrahmen.



Produktbeschreibung

Funktionen und Vorteile

- Empfohlen für die Befestigung von ITE auf sup Holzport mit UC-Schrauben und auf Metallträger mit WB-Schrauben.
 - Reduzierung des Wärmebrückeneffekts dank des speziellen Kappendesigns.
 - Homogene Haltekraft.
 - Schnelle, einfache und saubere Installation.
 - Kann mit einer Stützrosette verwendet werden
- Zusätzlicher KWL von Durchmesser 90, 110 oder 140mm.

Anwendungen

- Äußeres Wärmedämmsystem (WDVS)
- Platten aus expandiertem Polystyrol (EPS).
- Mineralwolle
- Isolierplatten auf Basis von Polystyrol

Klammern

Zur Verwendung in:

- Stahlblech- und Metallprofile
- Trinken

Implementierung



1. Führen Sie die KC-Unterlegscheibe vorsichtig in die Isolierung ein.
2. Ziehen Sie eine geeignete Schraube bis zur richtigen Tiefe durch die Unterlegscheibe und die Isolierschicht in die Halterung ein.
3. Bei Holzstützen wird empfohlen, die Unterlegscheibe mit einer gehärteten UC-Schraube zu montieren.
4. Bei Stahlstützen wird empfohlen, die Unterlegscheibe mit einer selbstbohrenden WB- oder WX-Schraube zu installieren.

Produktbeschreibung

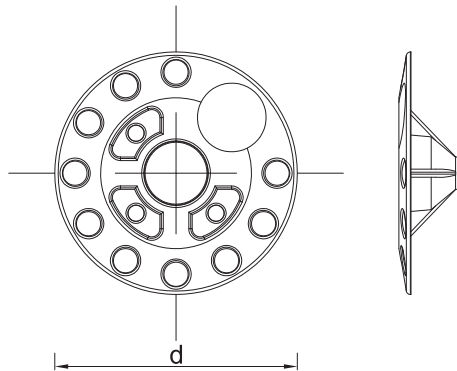

Abmessungen	Produktcode	Knöchel			Teil zum Reparieren
		Schraubendurchmesser	Länge	Rosettendurchmesser	Maximale Dicke
		d	L	D	t _{fix}
[mm]					
KC mit Holzschrauben					
Ø5	KC + UC-5050	5	50	60	30
	KC + UC-5060	5	60	60	40
	KC + UC-5070	5	70	60	50
	KC + UC-5080	5	80	60	60
	KC + UC-5090	5	90	60	70
	KC + UC-50100	5	100	60	80
Ø6	KC + UC-60100	6	100	60	75
	KC + UC-60120	6	120	60	95
	KC + UC-60140	6	140	60	115
	KC + UC-60160	6	160	60	135
	KC + UC-60200	6	200	60	175
KC mit selbstbohrender Stahlblechschraube					
Ø5	KC + WB-48100	4,8	100	60	90
	KC + WB-48120	4,8	120	60	110
	KC + WB-48140	4,8	140	60	130
	KC + WB-48160	4,8	160	60	150
	KC + WB-48170	4,8	170	60	160
	KC + WB-48180	4,8	180	60	170
	KC + WB-48200	4,8	200	60	190
	KC + WB-48220	4,8	220	60	210

Technische Spezifikationen

Unterstützung			Holz		Stahlblech
	h _{nom}	[mm]	20	25	0.75
Gesamttiefe des Ankers	h _{nom}	[mm]	20	25	0.75
Mindest. Mediendicke	h _{min}	[mm]	20	25	0.75
Mindestabstand zwischen den Achsen	s _{min}	[mm]	100	100	100
Mindestrandabstand	c _{min}	[mm]	100	100	100
Knöcheldurchmesser	d	[mm]	5	6	4,8

Basisleistungsdaten

Daten für eine einzelne Befestigung ohne Einfluss benachbarter Kanten und Anschlüsse

Unterstützung		Holz	Holz	Stahlblech
Effektive Verankerungstiefe h_{ef}	[mm]	20	25	0.75
BRUCHLAST $N_{Ru,m}$				
KC + UC ø5	[kN]	0.78	-	-
KC + UC ø6	[kN]	-	0.98	-
KC + WB	[kN]	-	-	0.86
CHARAKTERISTISCHER WIDERSTAND N_{Rk}				
KC + UC ø5	[kN]	0.73	-	-
KC + UC ø6	[kN]	-	0.91	-
KC + WB	[kN]	-	-	0.81
BERECHNUNGSWERT N_{Rd}				
KC + UC ø5	[kN]	0.36	-	-
KC + UC ø6	[kN]	-	0.45	-
KC + WB	[kN]	-	-	0.40
EMPFOHLENER WERT N_{rec}				
KC + UC ø5	[kN]	0.26	-	-
KC + UC ø6	[kN]	-	0.32	-
KC + WB	[kN]	-	-	0.29
Knöchel		KC		
Steifigkeit der Rosette	[kN/mm]	0.4		

Logistikdaten

Abmessungen	Produktcode	Knöchel		Durchmesser der Rosette [mm]	Schrauben		Menge [Stück]			Gewicht (kg)			Barcode
		Diamètre de la vis [mm]	Länge [mm]		Länge [mm]	Behälter	Einpacken	Palette	Behälter	Einpacken	Palette		
ø5	KC + UC-5050	5	50	60									
	KC + UC-5060	5	60	60									
	KC + UC-5070	5	70	60									
	KC + UC-5080	5	80	60									
	KC + UC-5090	5	90	60									
	KC + UC-50100	5	100	60									
ø6	KC + UC-60100	6	100	60									
	KC + UC-60120	6	120	60									
	KC + UC-60140	6	140	60									
	KC + UC-60200	6	200	60									
ø5	KC + WB-48100	4.8	100	60									
	KC + WB-48120	4.8	120	60									
	KC + WB-48140	4.8	140	60									
	KC + WB-48160	4.8	160	60									
	KC + WB-48170	4.8	170	60									
	KC + WB-48180	4.8	180	60									
	KC + WB-48200	4.8	200	60									
ø4.8	R-WX-48T050				50	250	3000	72000	1.17	14.1	367.8	5906675104157	
	R-WX-48T060				60	250	3000	72000	1.39	16.6	429.5	5906675104164	
	R-WX-48T070				70	250	3000	72000	1.61	19.3	492.2	5906675104171	
	R-WX-48T080				80	250	3000	72000	1.86	22.3	564.8	5906675104188	
	R-WX-48T100				100	200	2400	57600	1.86	22.4	566.8	5906675104201	
	R-WX-48T120				120	200	2400	57600	2.2	26.9	675.4	5906675104232	
	R-WX-48T140				140	200	2400	57600	2.6	31.3	780.2	5906675104256	

Logistische Daten

Abmessungen	Produktcode	Knöchel			Schrauben Länge [m m]	Menge [Stück]			Gewicht (kg)			Barcode
		Diamètre de la vis [mm]	Länge [mm]	Durchmes- ser der Rosette		Behälter	Einpac- ken	Palette	Behälter	Einpac- ken	Palette	
Ø4.8	R-WX-48T160				160	100	1200	28800	1.51	18.1	463.7	5906675104263
	R-WX-48T180				180	100	100	16800	1.75	1.75	324.7	5906675104270
	R-WX-48T200				200	100	100	16800	1.93	1.93	353.6	5906675104287
	R-WX-48T240				240	100	100	16800	2.3	2.3	408.8	5906675104300
	R-WX-48T300				300	100	100	16800	2.8	2.8	498.0	5906675104317
	R-WO-48T060				60	250	3000	72000	1.38	16.6	428.6	5906675104676
	R-WO-48T080				80	250	3000	72000	1.81	21.7	551.6	5906675104683
	R-WO-48T100				100	200	3200	76800	1.85	29.6	741.2	5906675104690
	R-WO-48T120				120	200	3200	76800	2.1	33.9	842.9	5906675104706
	R-WO-48T140				140	200	2400	57600	2.5	30.4	760.4	5906675104713
	R-WO-48T160				160	100	1200	28800	1.59	19.1	488.2	5906675104720
	R-WO-48T180				180	100	100	16800	1.83	1.83	337.8	5906675104744
	R-WO-48T200				200	100	100	16800	2.0	2.0	371.5	5906675104751
	R-WO-48T240				240	100	100	16800	2.2	2.2	399.9	5906675104768
	R-WO-48T300				300	100	100	16800	2.7	2.7	485.8	5906675104775
Ø6.1	R-WBT-61050				50	100	3200	76800	0.79	25.2	634.4	5906675101200
	R-WBT-61075				75	100	1600	38400	1.11	17.7	454.3	5906675101231
	R-WBT-61090				90	100	1600	38400	1.34	21.4	543.8	5906675101309
	R-WBT-61100				100	100	1600	38400	1.49	23.9	602.5	5906675101408
	R-WBT-61120				120	100	1200	28800	1.77	21.3	540.9	5906675101439
	R-WBT-61140				140	100	1200	28800	2.0	24.5	618.7	5906675101460
	R-WBT-61160				160	100	1200	28800	2.3	28.1	704.2	5906675101514
	R-WBT-61180				180	100	100	16800	2.7	2.7	477.9	5906675225173
	R-WBT-61200				200	100	100	16800	2.9	2.9	518.5	5906675101927
	R-WBT-61220				220	100	100	16800	3.2	3.2	568.4	5906675102214
	R-WBT-61240				240	100	100	16800	3.5	3.5	620.7	5906675102245
	R-WBT-61260				260	100	100	16800	3.8	3.8	661.7	5906675102269
	R-WBT-61300				300	100	100	7800	4.3	4.3	367.0	5906675102290

FREIE DEUTSCHE ÜBERSETZUNG
ADAM MATERIAUX

KC Insulation washer

Insulation washer with integral cap suitable for attachment of insulation layers to wooden and sheet metal substrates.



Product information

Features and benefits

- Recommended for the attachment of ETICS to wooden substrates using UC screws, or to sheet metal using WB screws.
- Special design of integral fastener cap allows reduction of thermal bridges.
- Consistent and reliable holding force
- Quick, simple and clean installation.
- Can be used in combination with additional KWL plate - 90, 110 or 140mm diameter.

Applications

- External Thermal Insulation Composite Systems (ETICS)
- Polystyrene (EPS) boards
- Mineral wool (MW) boards
- Polyurethane (PU) boards

Base materials

Approved for use in:

- Metal Sheet & Profiles
- Wood

Installation guide



1. Lightly insert KC washer into surface of insulation material.
2. Drive the required screw through the washer and insulation material into the substrate, until fixing depth is reached.
3. In wooden substrates the washer is recommended for use with the UC chipboard screw.
4. In sheet metal the washer is recommended for use with either the WB or WX self-drilling screw.

Product information

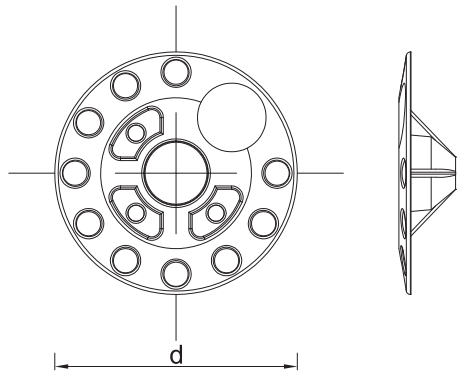

Size	Product Code	Fixing			Fixture
		Screw diameter	Length	Plate diameter	Max. thickness
		d	L	D	t _{fix}
[mm]					
KC with screw to wood					
Ø5	KC + UC-5050	5	50	60	30
	KC + UC-5060	5	60	60	40
	KC + UC-5070	5	70	60	50
	KC + UC-5080	5	80	60	60
	KC + UC-5090	5	90	60	70
	KC + UC-50100	5	100	60	80
Ø6	KC + UC-60100	6	100	60	75
	KC + UC-60120	6	120	60	95
	KC + UC-60140	6	140	60	115
	KC + UC-60160	6	160	60	135
	KC + UC-60200	6	200	60	175
KC with selfdrilling screw to steel sheet					
Ø5	KC + WB-48100	4.8	100	60	90
	KC + WB-48120	4.8	120	60	110
	KC + WB-48140	4.8	140	60	130
	KC + WB-48160	4.8	160	60	150
	KC + WB-48170	4.8	170	60	160
	KC + WB-48180	4.8	180	60	170
	KC + WB-48200	4.8	200	60	190
	KC + WB-48220	4.8	220	60	210

Installation data

Substrate			Timber		Steel
Fixing diameter	d	[mm]	5	6	4.8
Hole diameter in substrate	d ₀	[mm]	-	-	-
Min. hole depth in substrate	h ₀	[mm]	-	-	-
Min. installation depth	h _{nom}	[mm]	20	25	0.75
Min. substrate thickness	h _{min}	[mm]	20	25	0.75
Min. spacing	s _{min}	[mm]	100	100	100
Min. edge distance	c _{min}	[mm]	100	100	100

Basic performance data

Performance data for single anchor without influence of edge distance and spacing

Substrate		Timber	Timber	Steel
Effective embedment depth h_{ef}	[mm]	20	25	0.75
MEAN ULTIMATE LOAD $N_{Rt,m}$				
KC + UC $\varnothing 5$	[kN]	0.78	-	-
KC + UC $\varnothing 6$	[kN]	-	0.98	-
KC + WB	[kN]	-	-	0.86
CHARACTERISTIC LOAD N_{Rk}				
KC + UC $\varnothing 5$	[kN]	0.73	-	-
KC + UC $\varnothing 6$	[kN]	-	0.91	-
KC + WB	[kN]	-	-	0.81
DESIGN LOAD N_{Rd}				
KC + UC $\varnothing 5$	[kN]	0.24	-	-
KC + UC $\varnothing 6$	[kN]	-	0.30	-
KC + WB	[kN]	-	-	0.44
RECOMMENDED LOAD N_{rec}				
KC + UC $\varnothing 5$	[kN]	0.17	-	-
KC + UC $\varnothing 6$	[kN]	-	0.22	-
KC + WB	[kN]	-	-	0.31
Fixing type		KC		
Plate stiffness	[kN/mm]	0.4		