

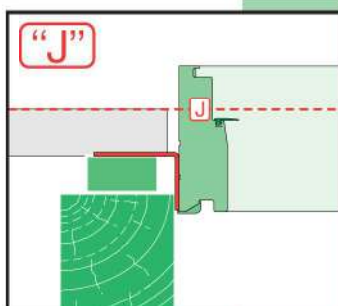

PTP, PTP-V

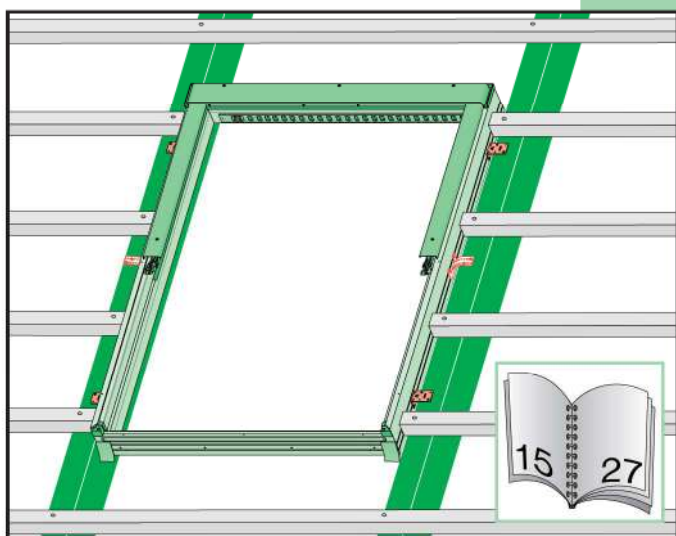

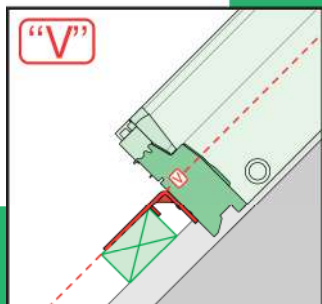
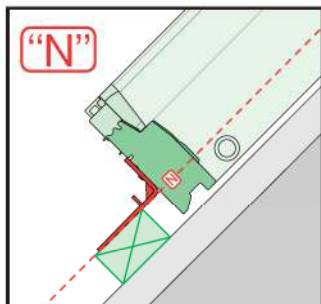
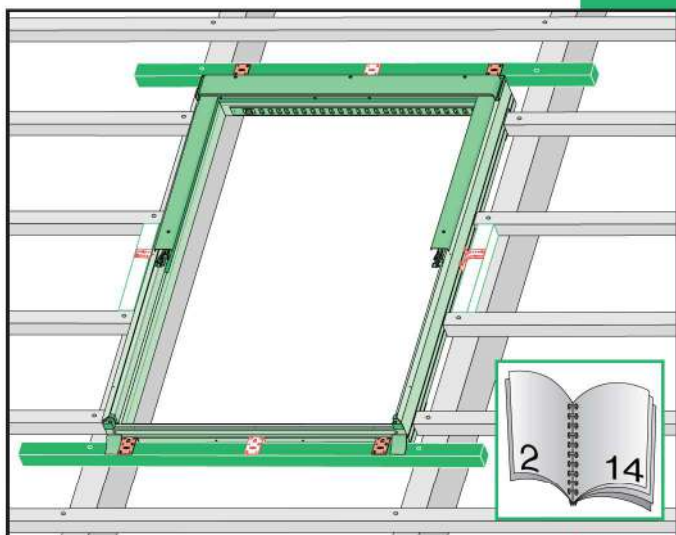

“N”, “V”

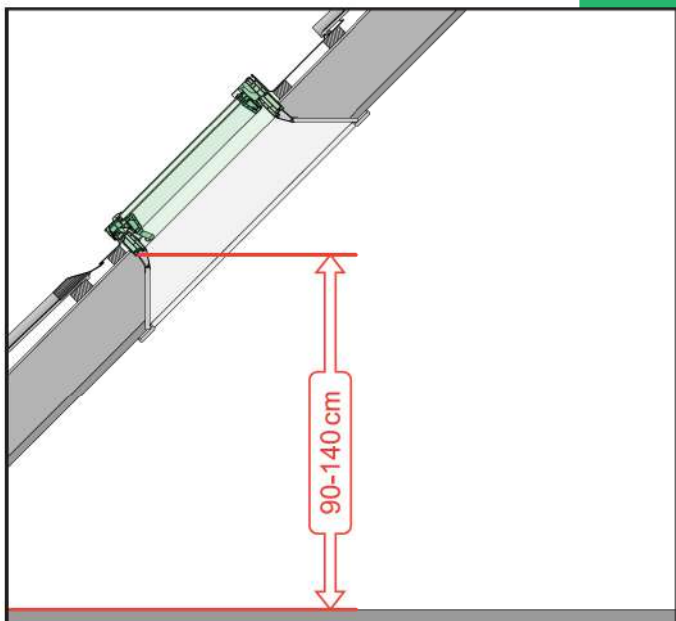
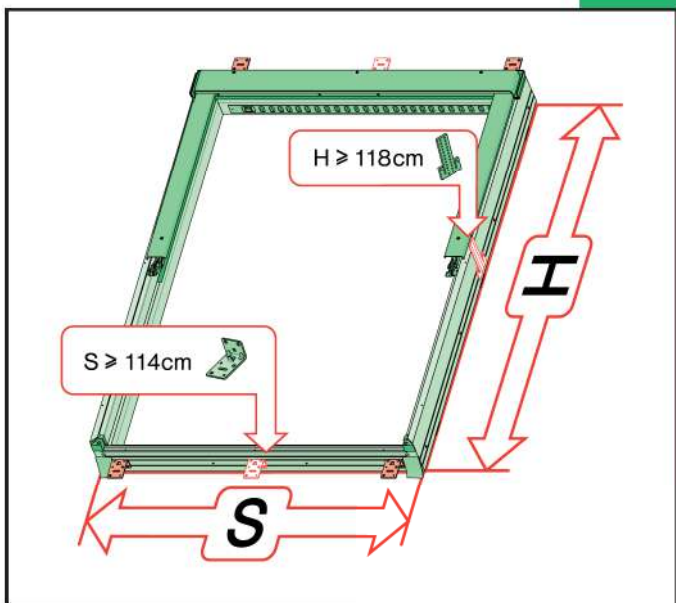
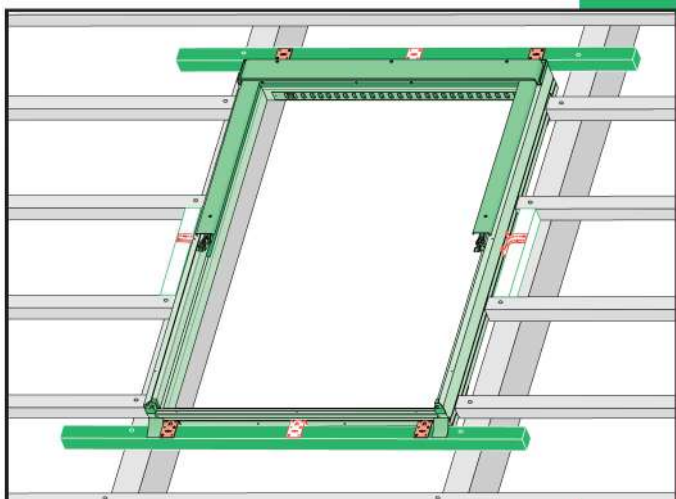

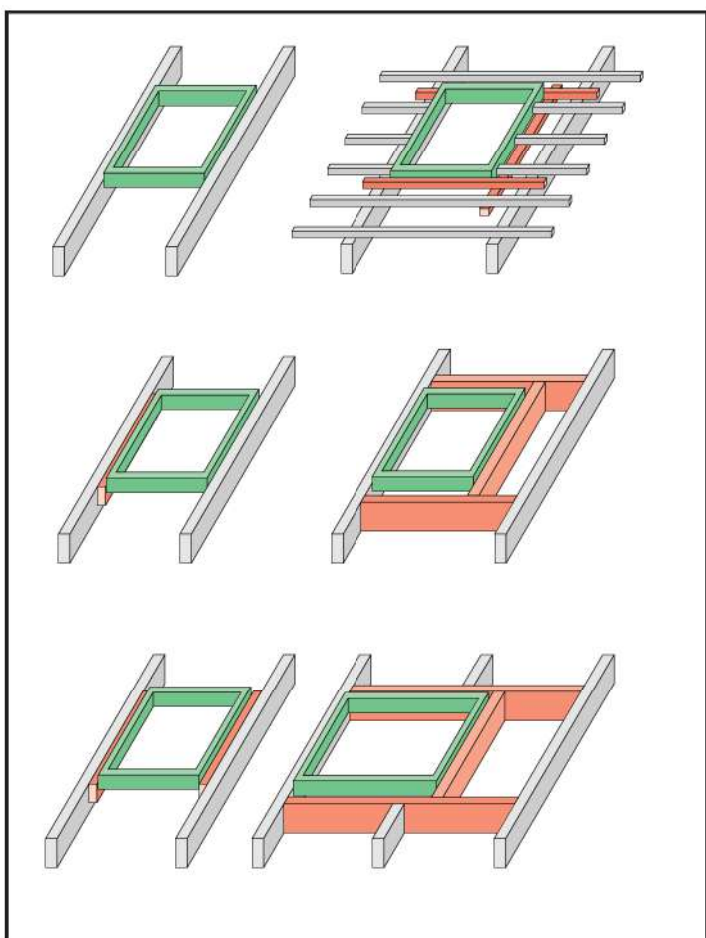
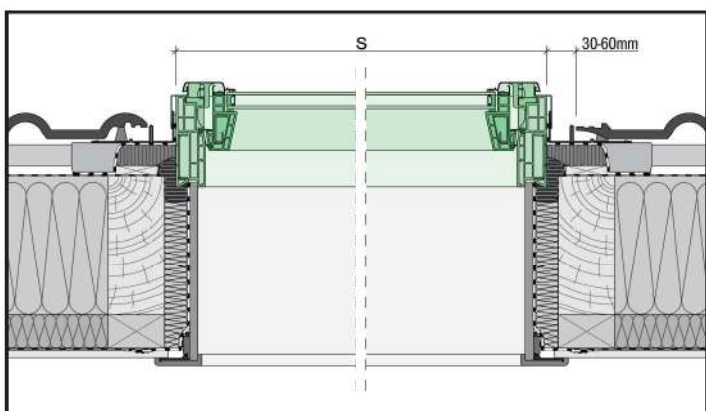
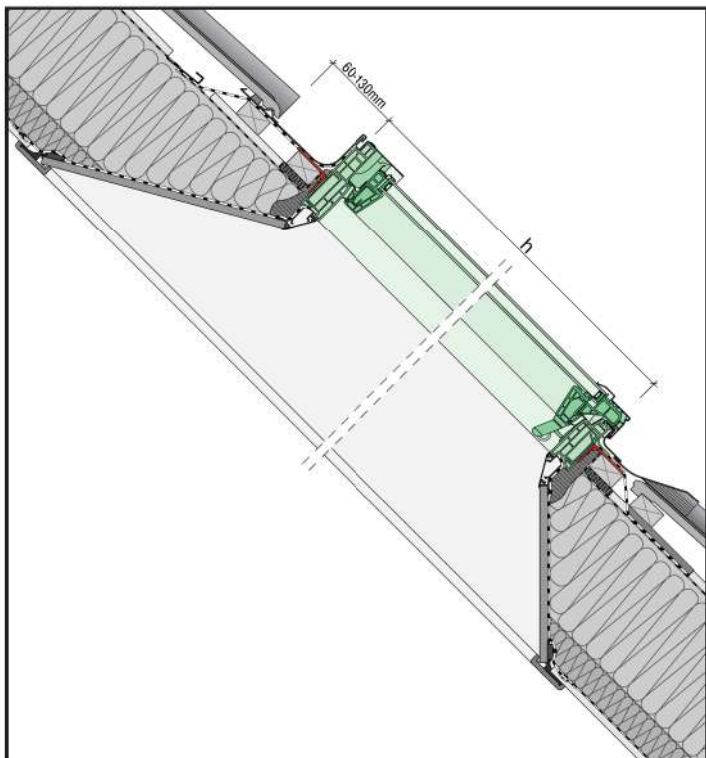



PTP-V

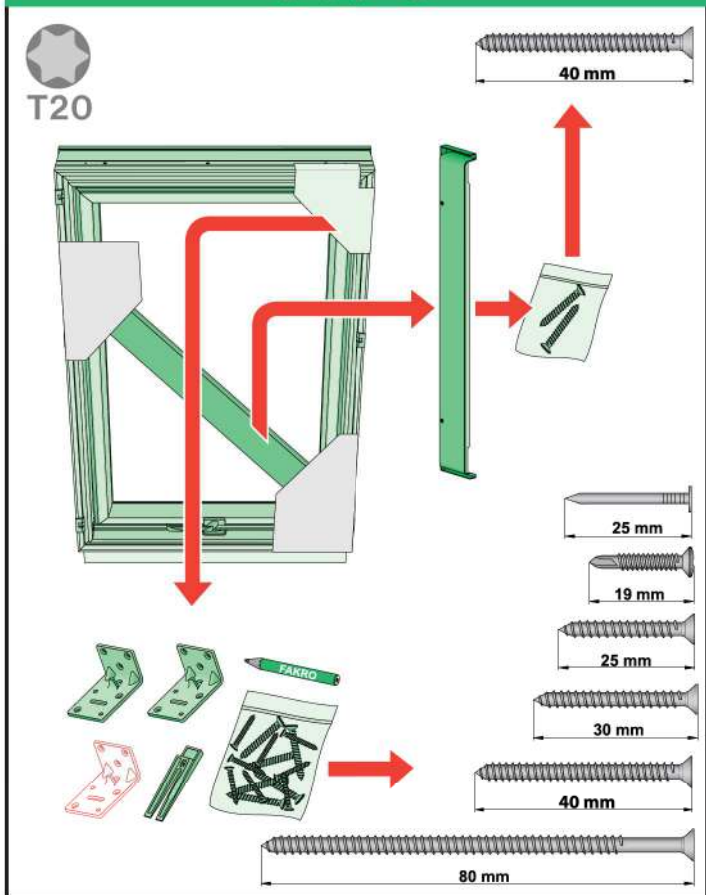

PTP

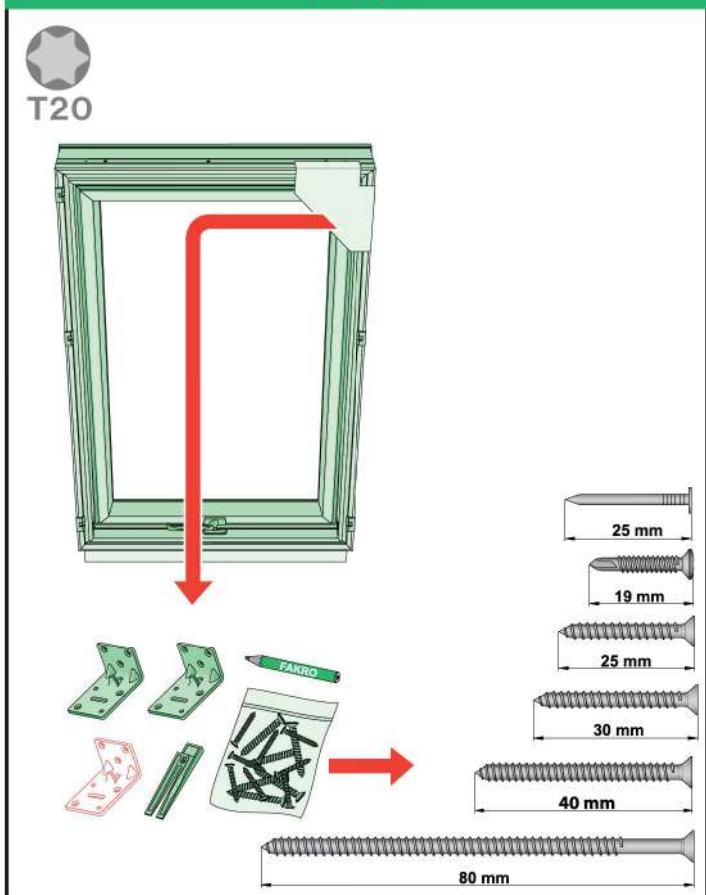

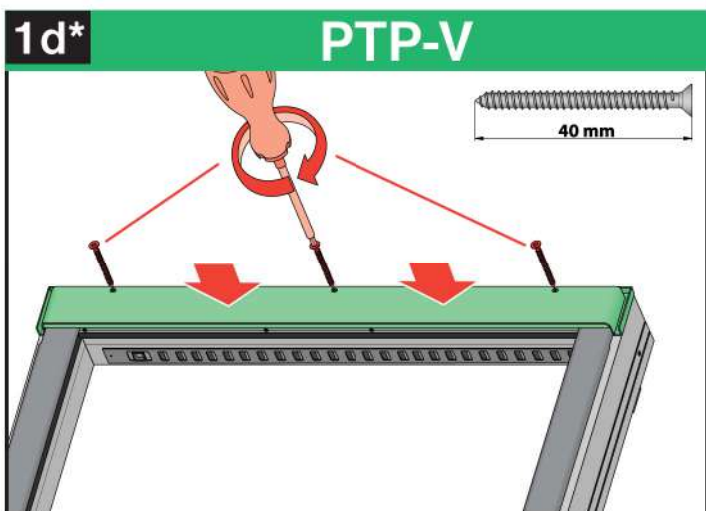
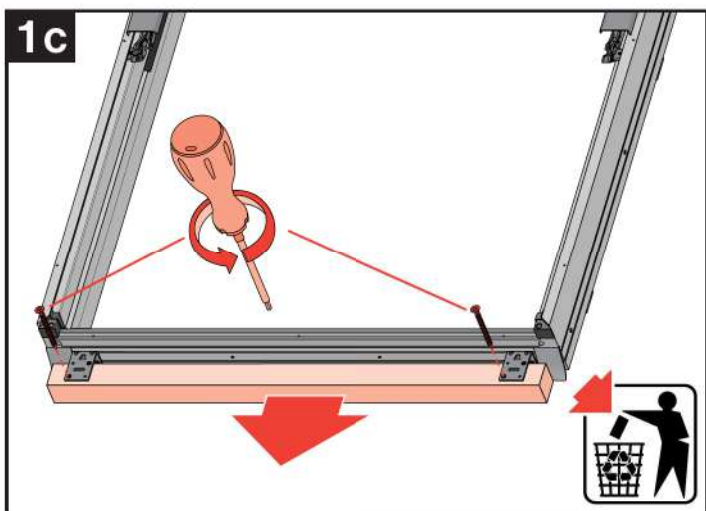
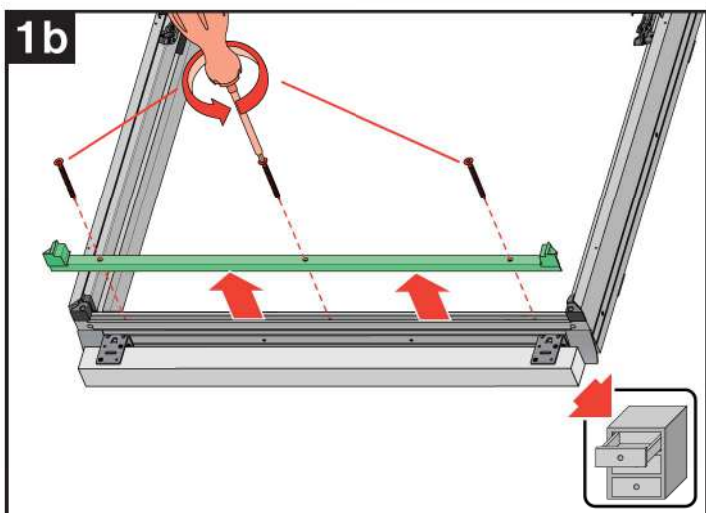
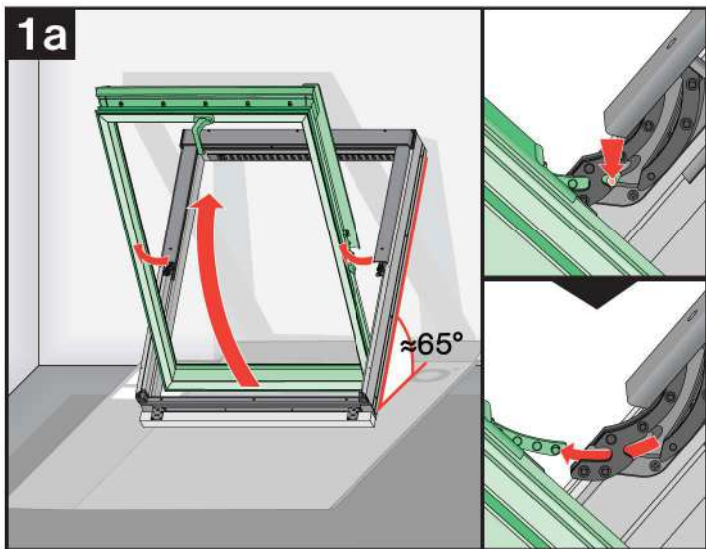

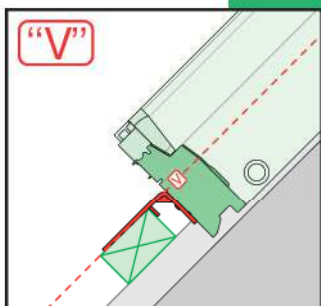
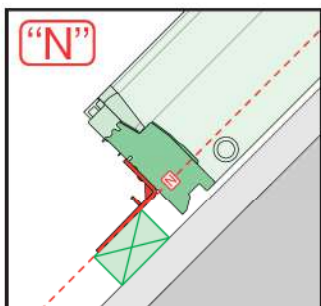
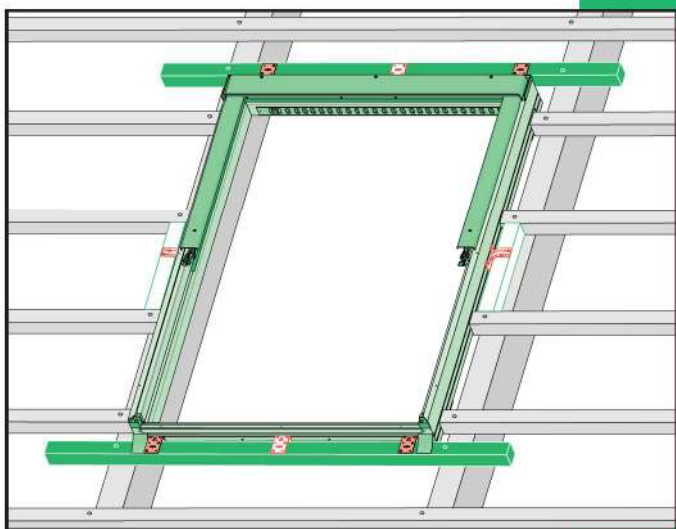

	<p>max 90mm</p>	EHN		
		EHV		
	<p>max 45mm</p>	EZN		
		EZV		
	<p>max 15mm (N) max 5mm (V)</p>	ELN		
		ELV		
	<p>max 5mm</p>	ESN		
		ESV		

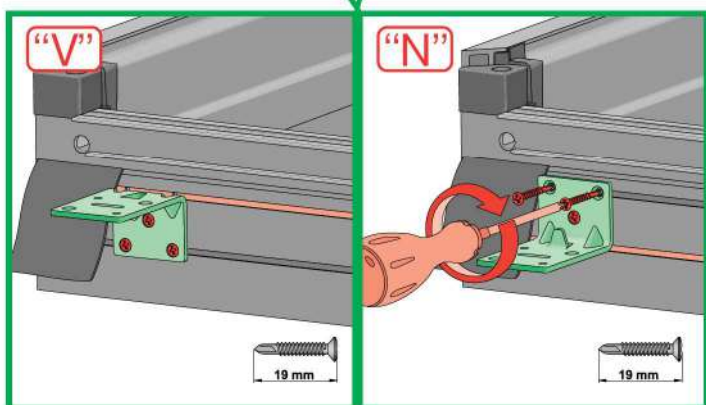
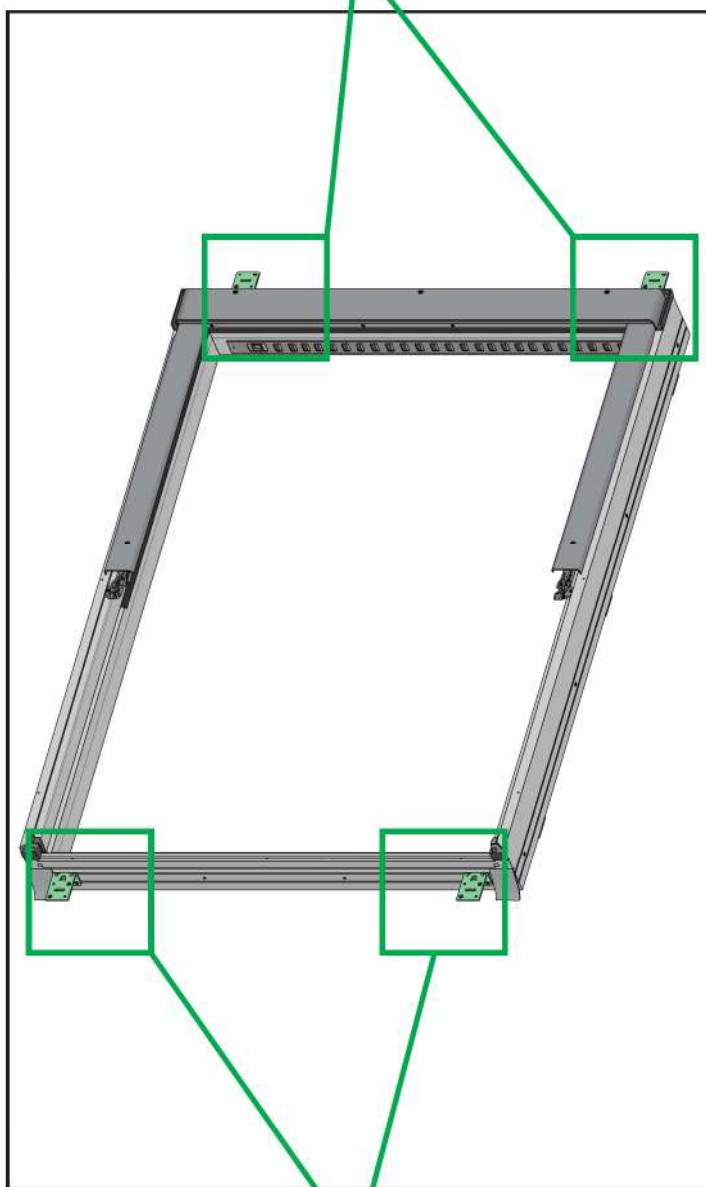
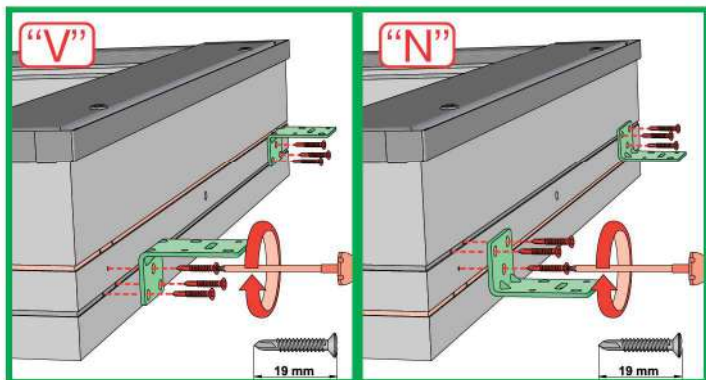

3a

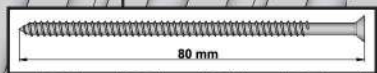
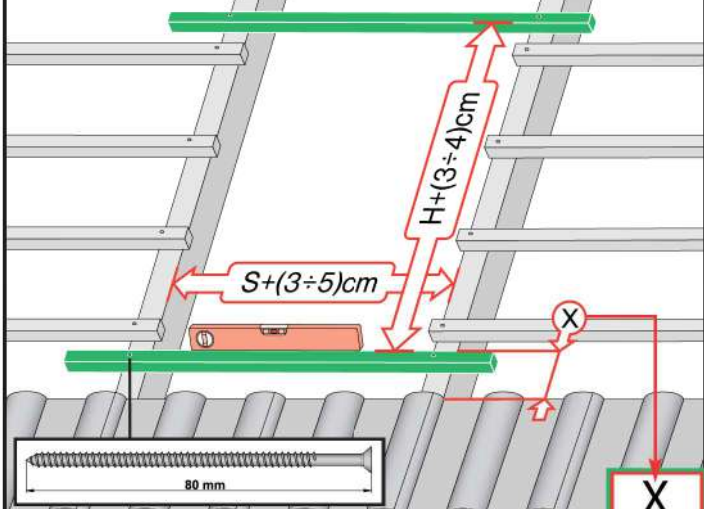
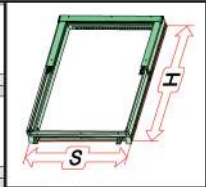

X

<p>max 90mm</p>	EHN EHV	7-10cm 7-10cm
<p>max 45mm</p>	EZN EZV	6-8cm 6-8cm
<p>380-420mm</p> <p>12-16mm</p>	EGV	6cm
<p>380-420mm</p> <p>12-16mm</p>	EPV	6cm
<p>max 5mm (V) max 15mm (N)</p>	ELN ELV	0-2cm 0-2cm
	EEN EEV	0-2cm 0-2cm

3b

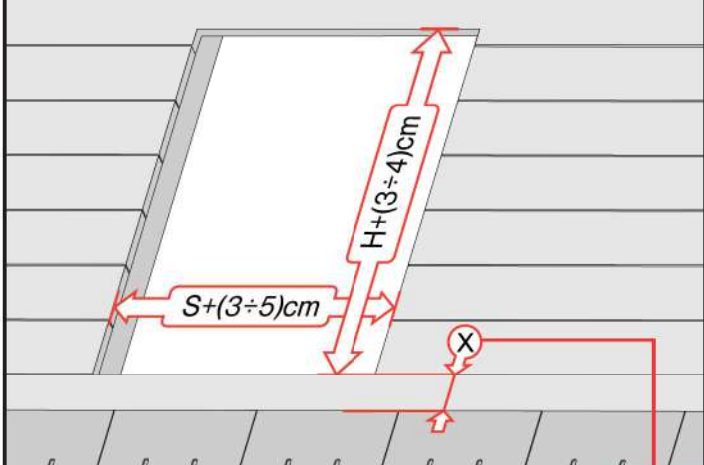
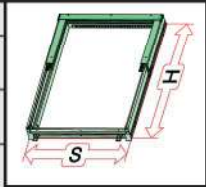

X

<p>max 5mm</p>	ESN ESV	0-2cm 0-2cm
----------------	------------	----------------

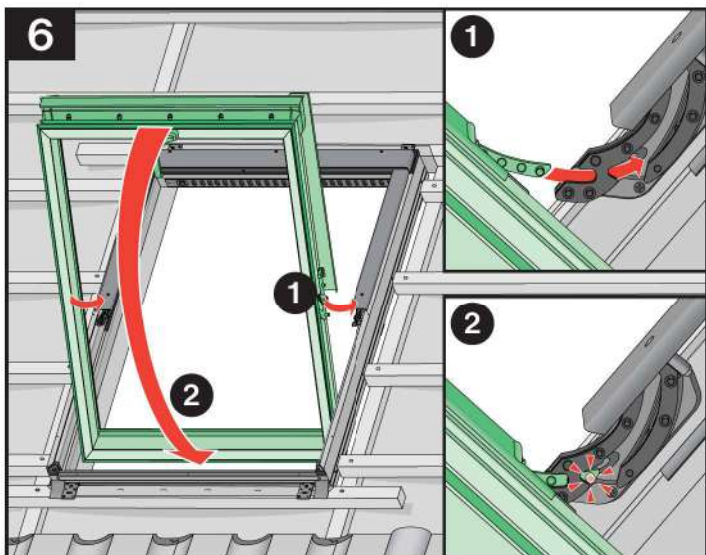
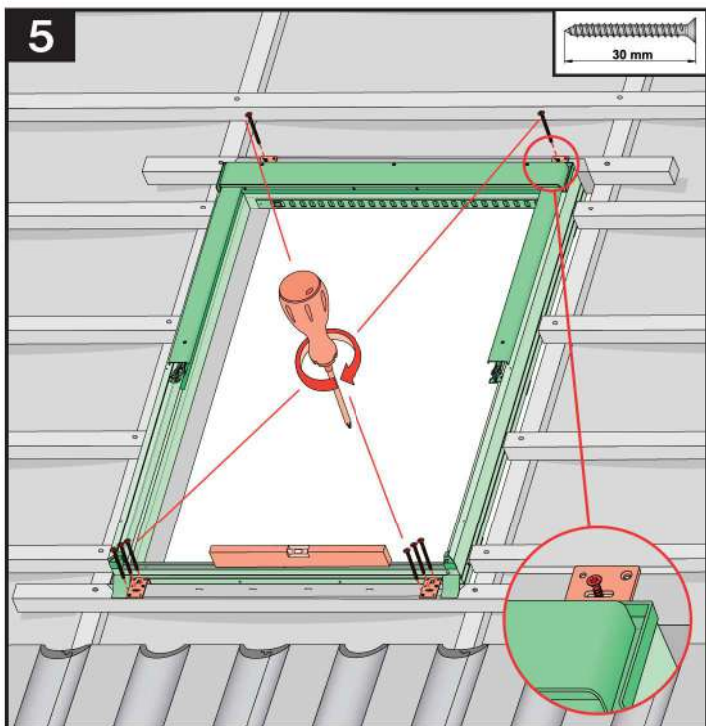
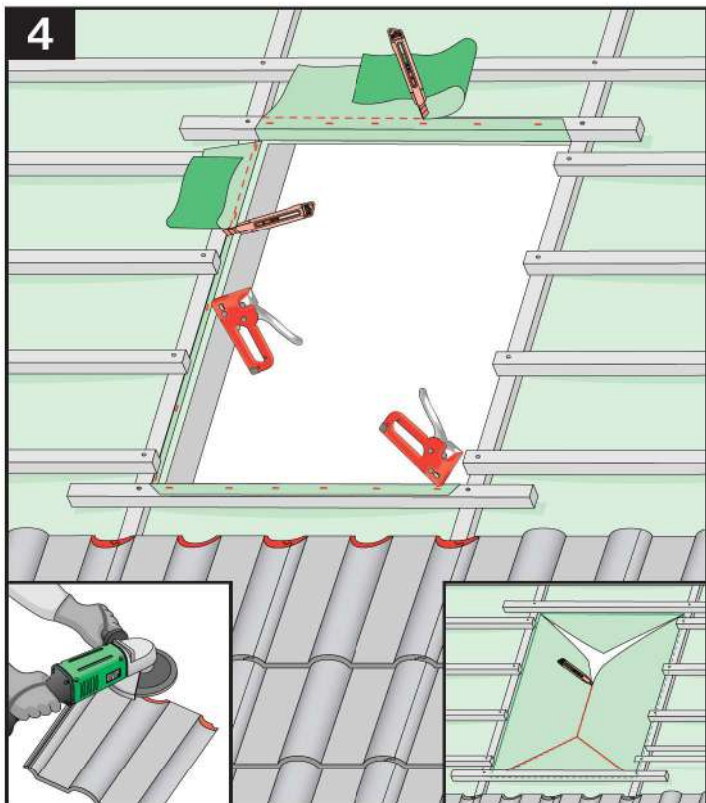

7

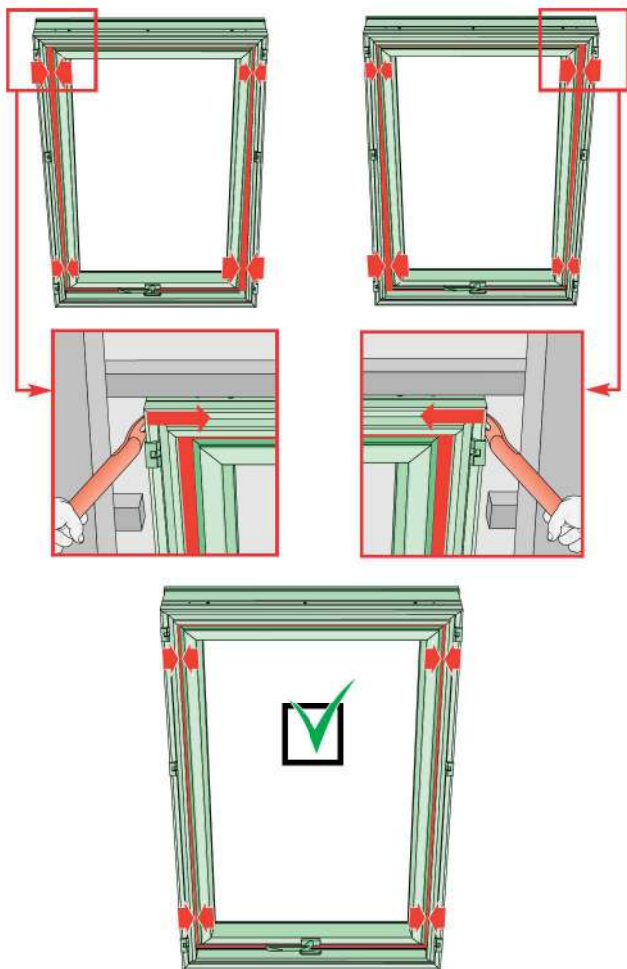

8

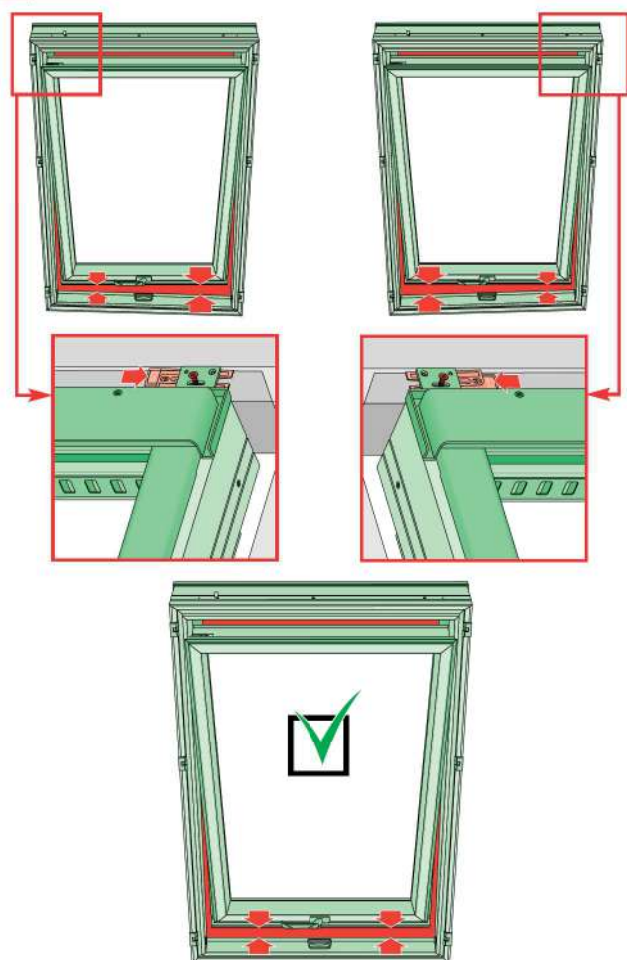

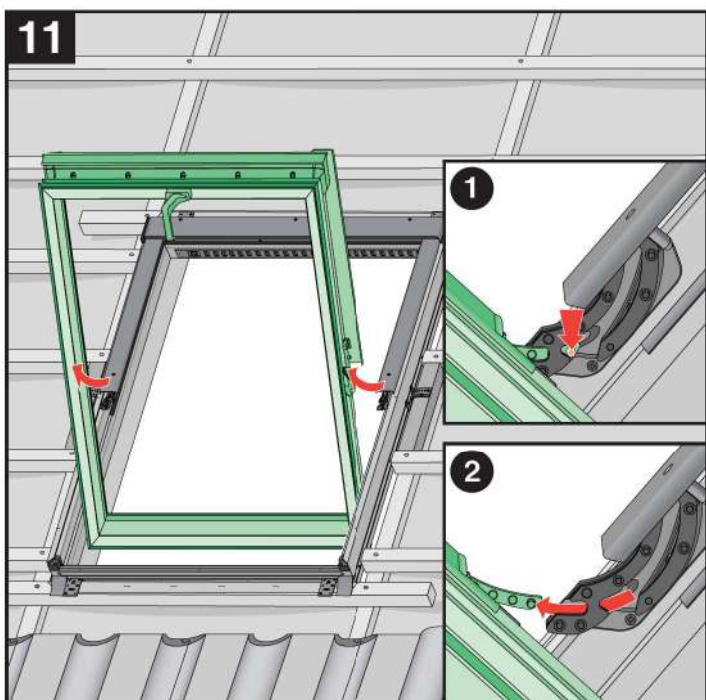
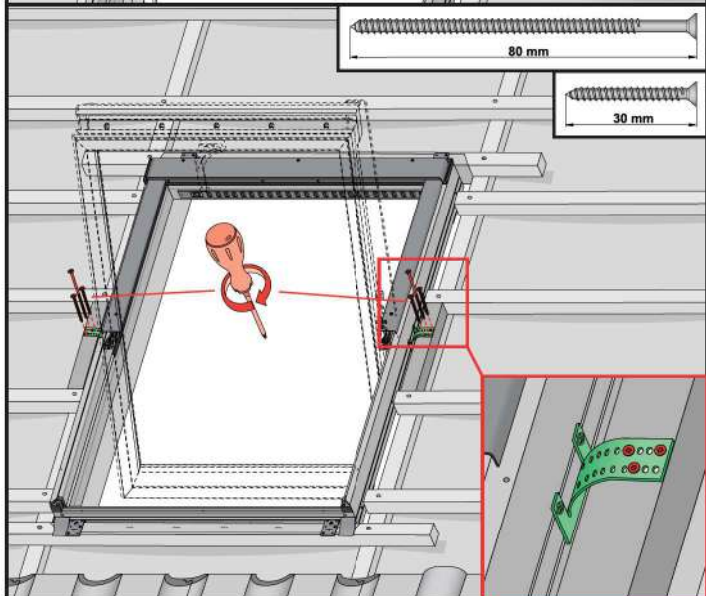
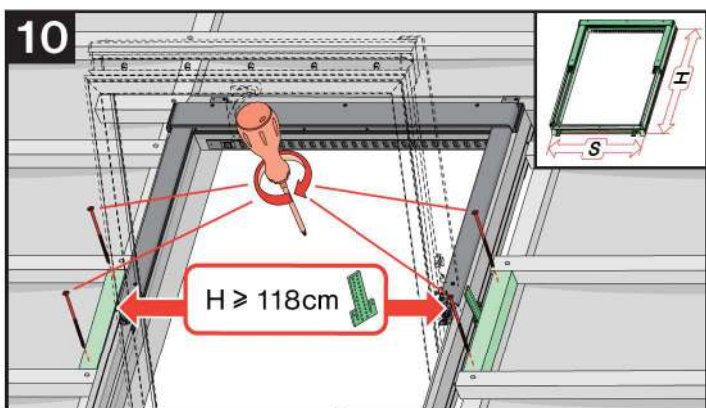
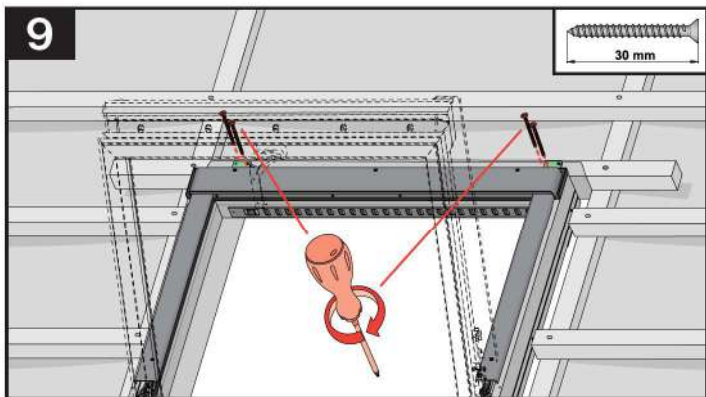

12

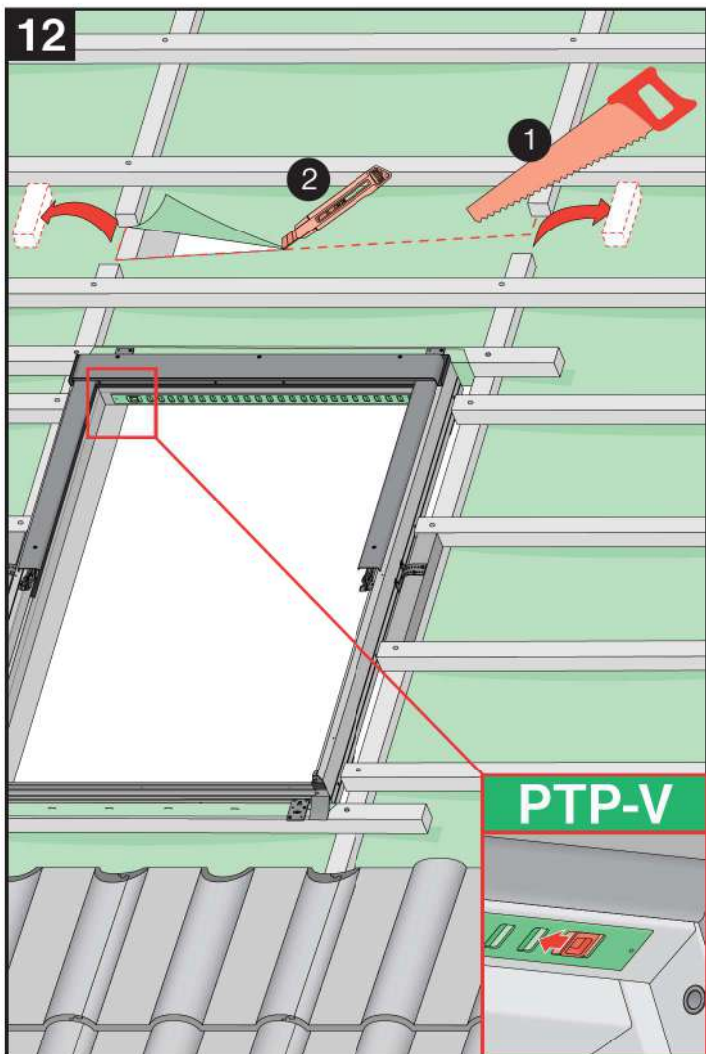

13

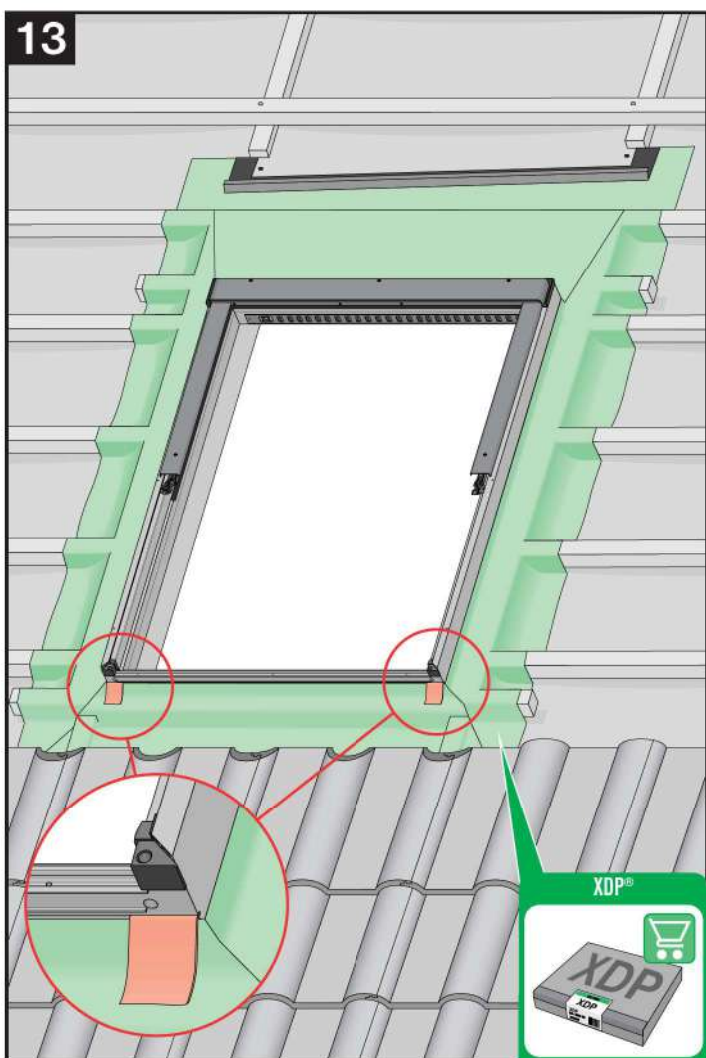

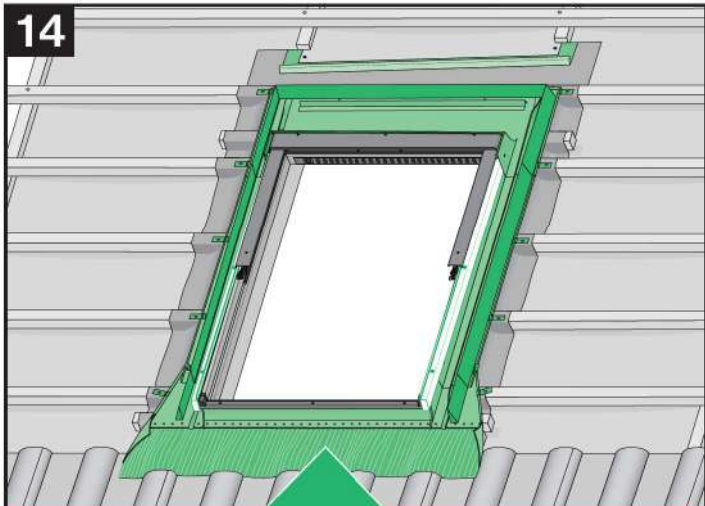

	max 90mm	EHN EHV
	max 45mm	EZN EZV
	max 5mm	ESN ESV
	12-16mm	EGV
	max 18mm	EPV
	max 5mm (V) max 15mm (N)	ELN ELV
		EEN EEV

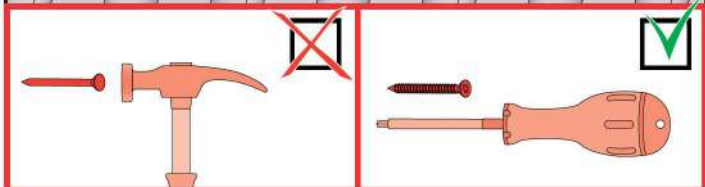
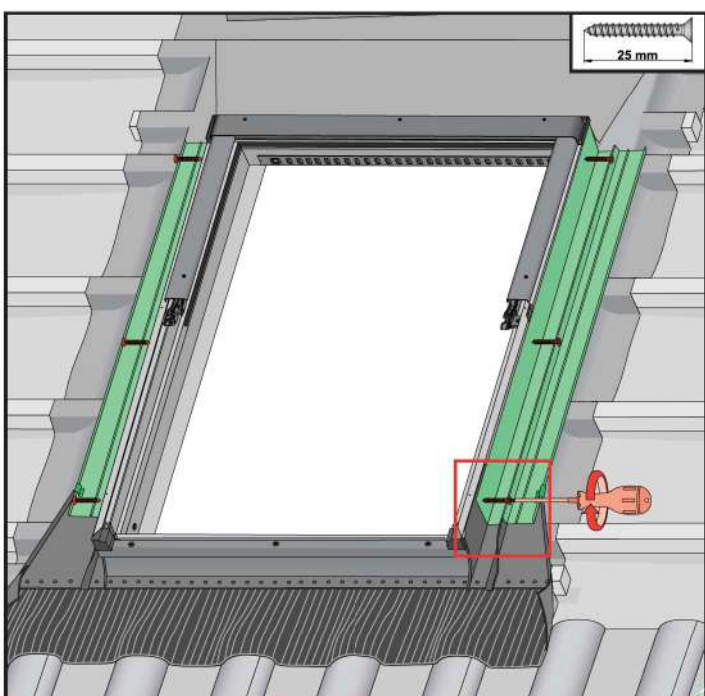

15

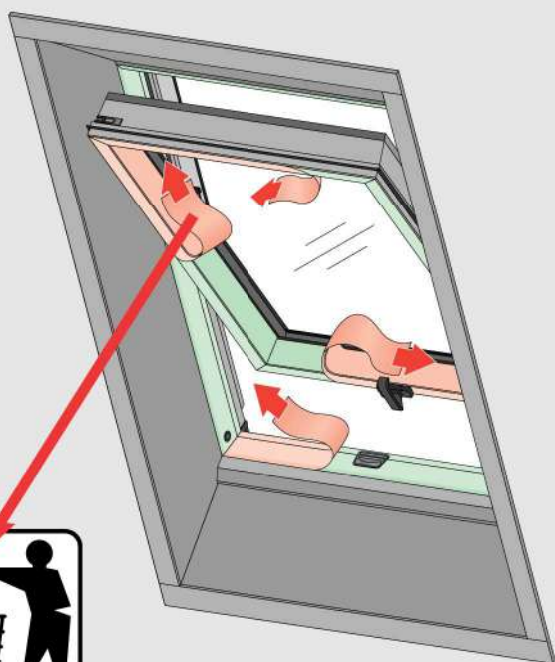

$a_1 = a_2$

$b_1 = b_2$

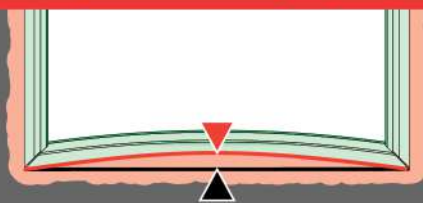
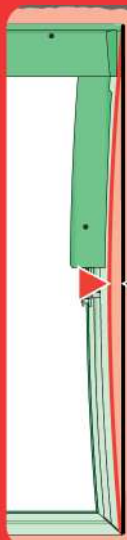
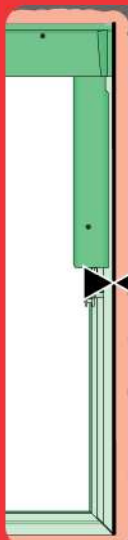
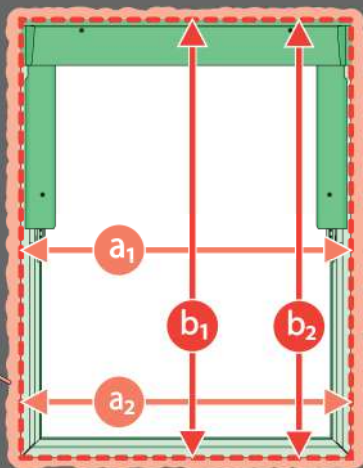



“J”

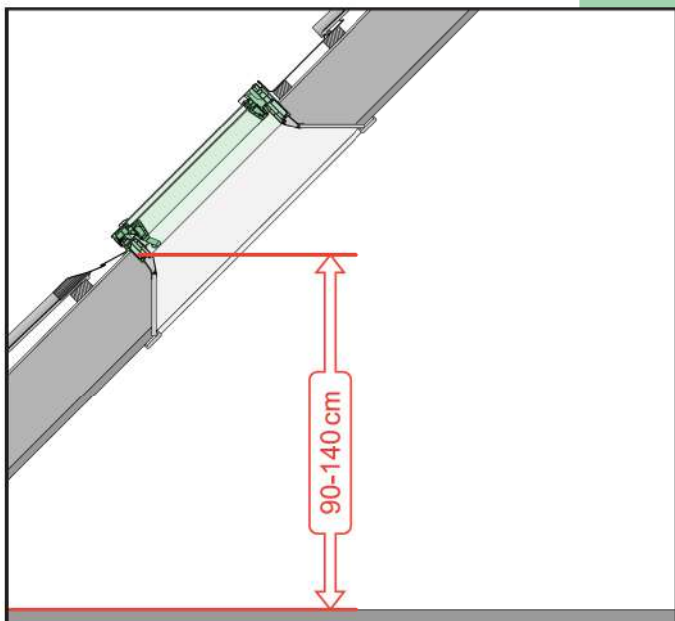
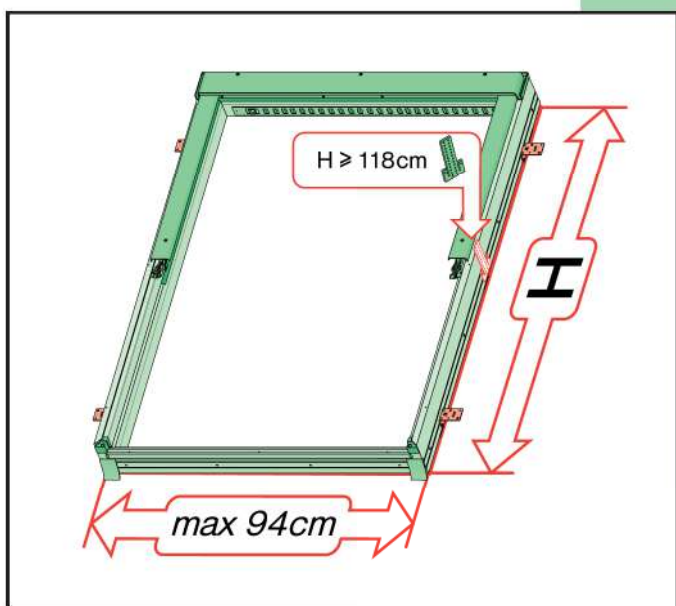
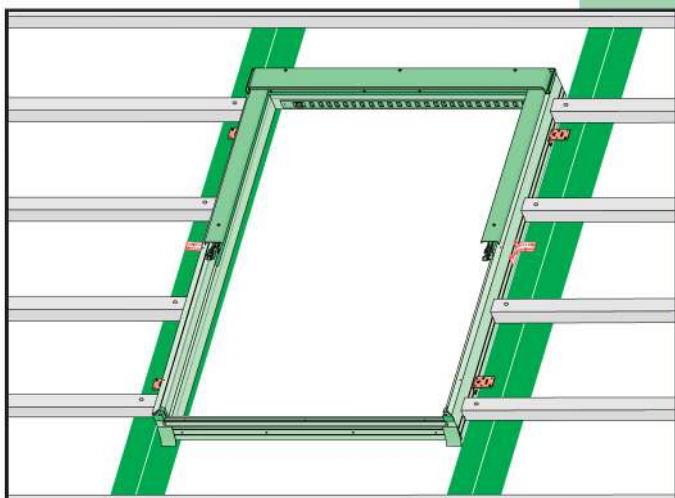

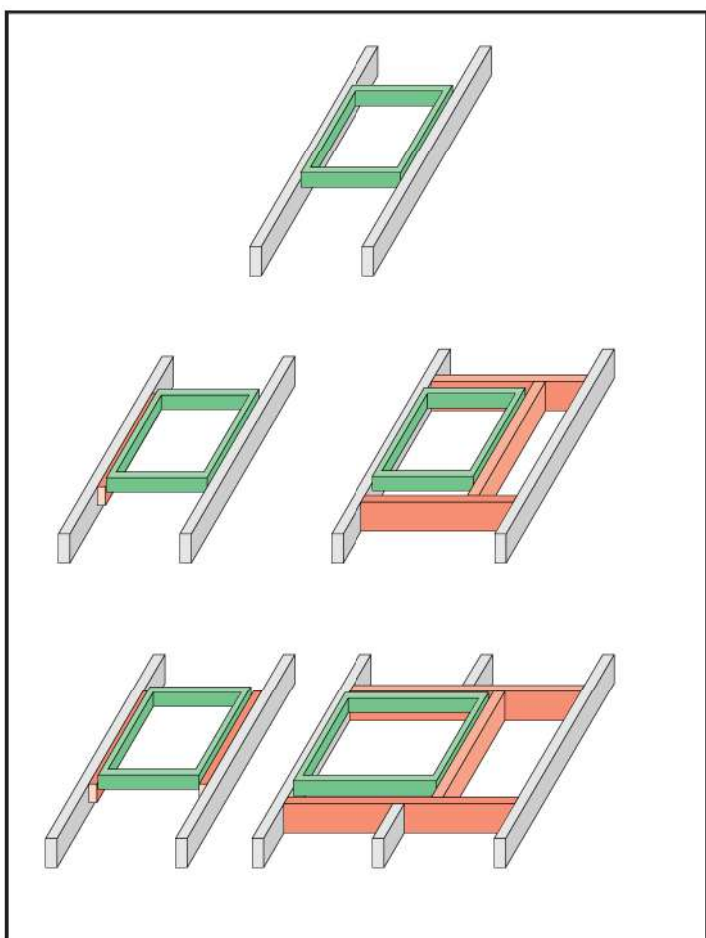
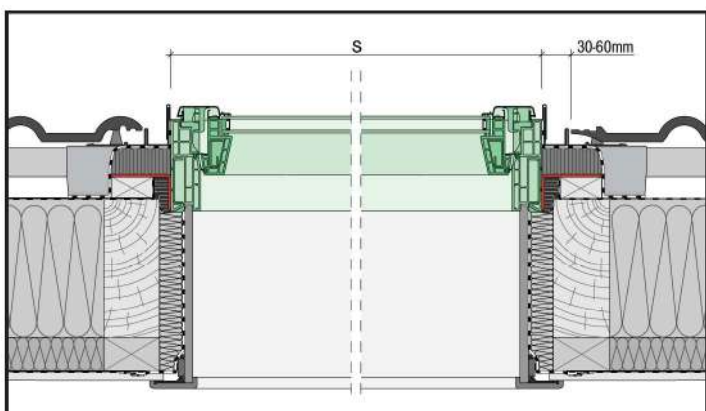
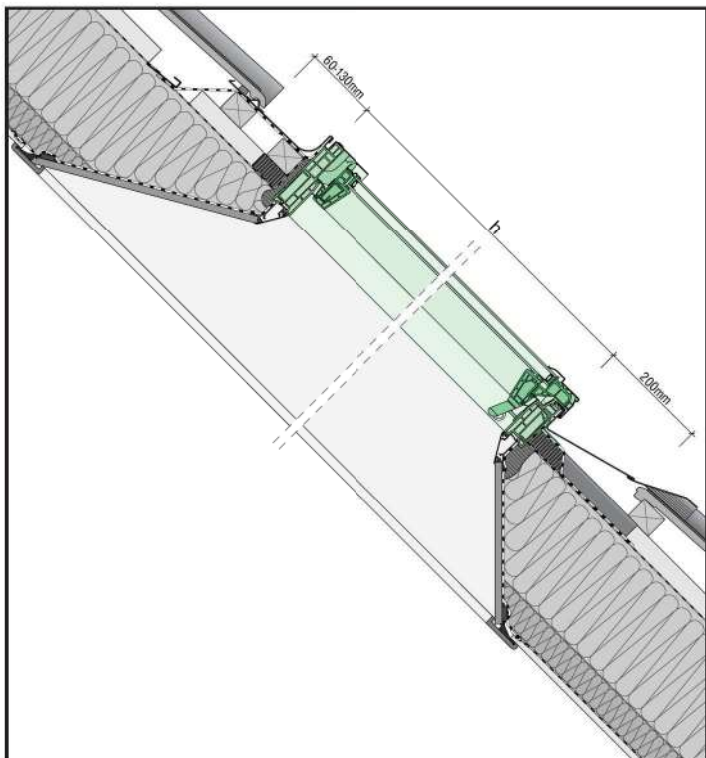



PTP-V

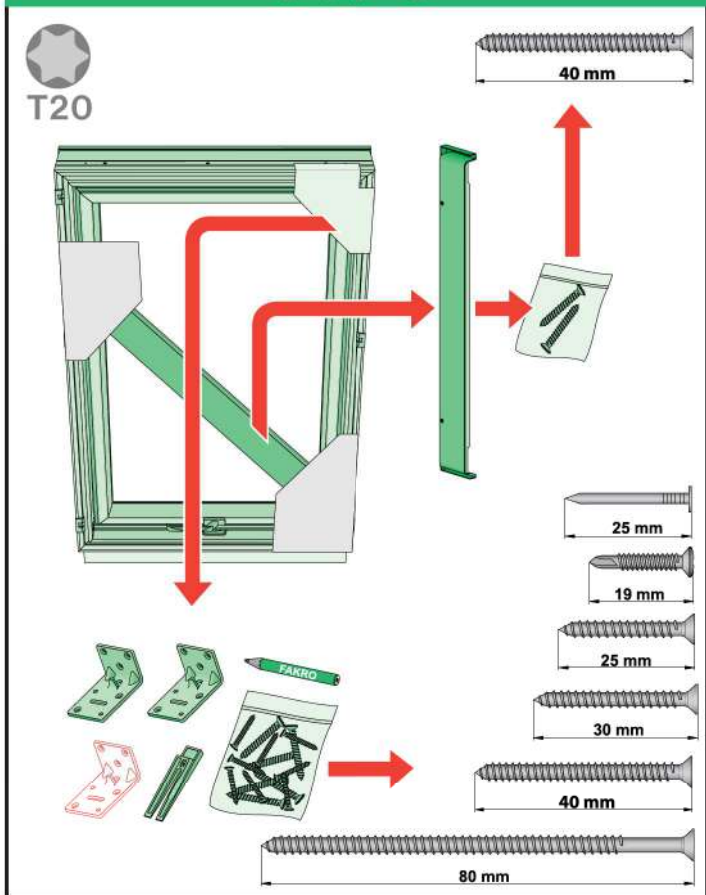

PTP

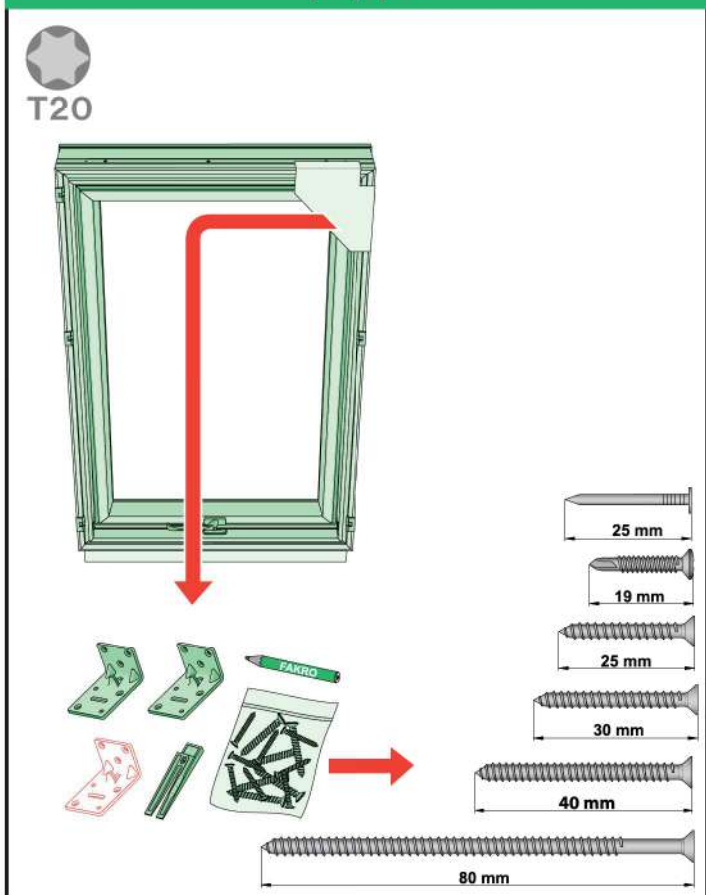

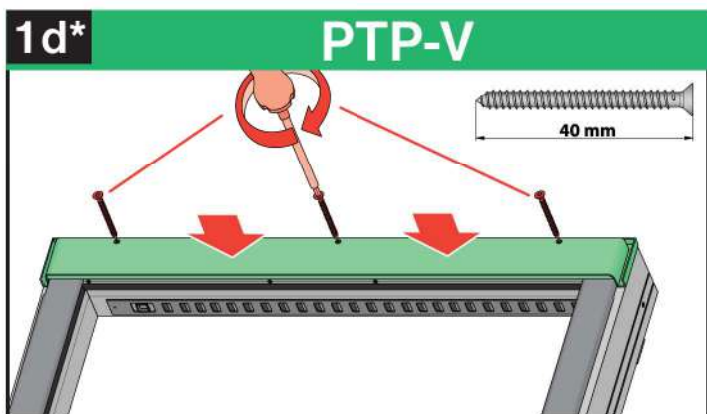
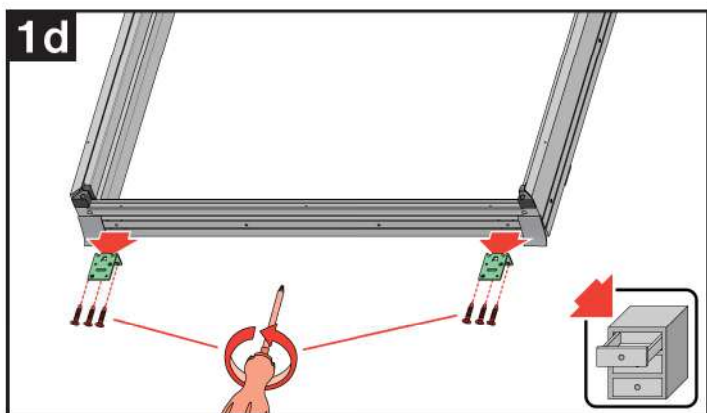
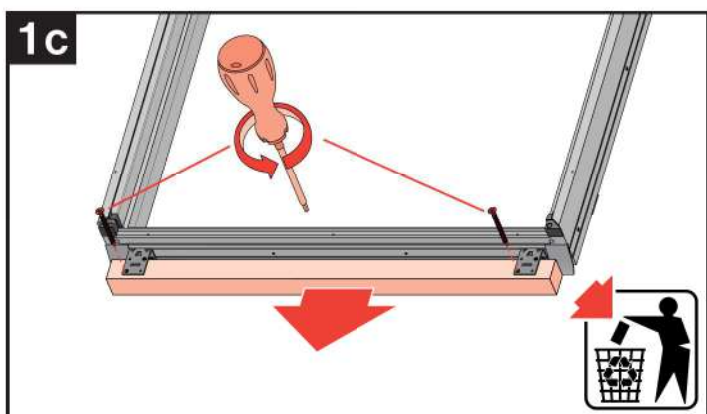
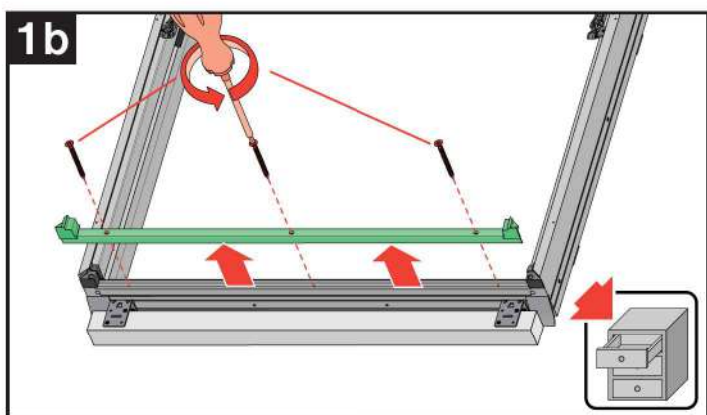
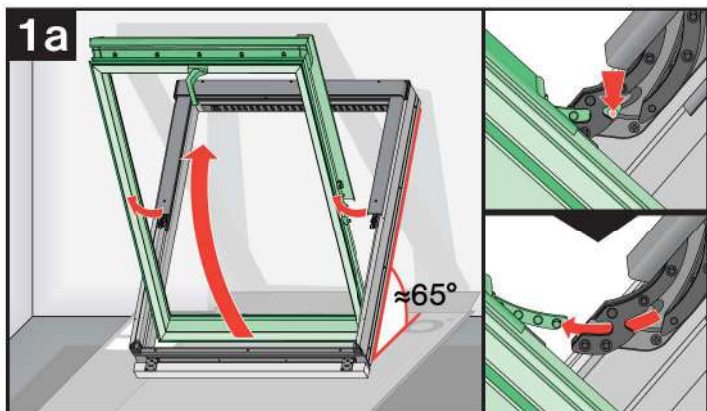

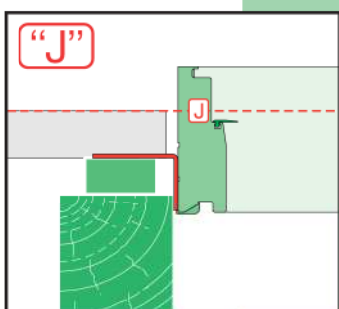
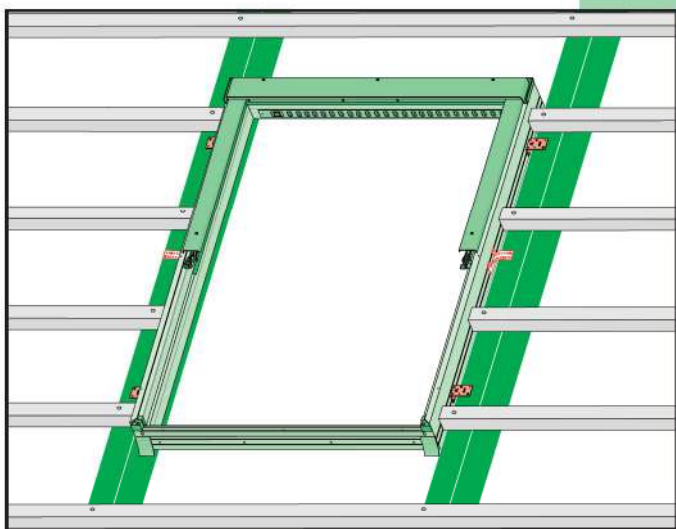

	<p>max 45mm</p>	<p>EZJ</p>

	<p>max 5mm</p>	<p>ELJ</p>

	<p>max 5mm</p>	<p>ESJ</p>

2

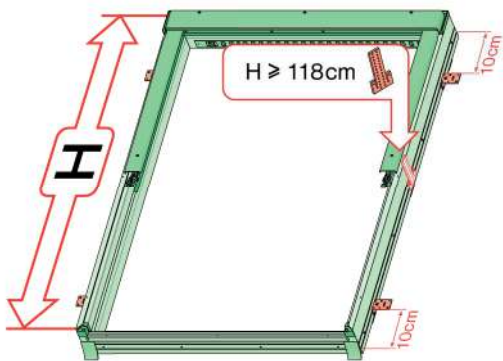

2a

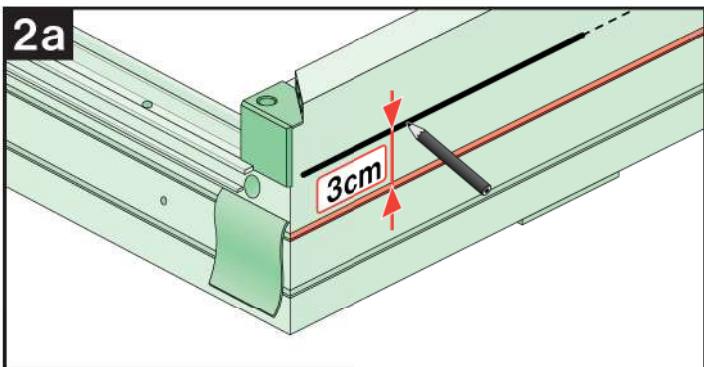

2b

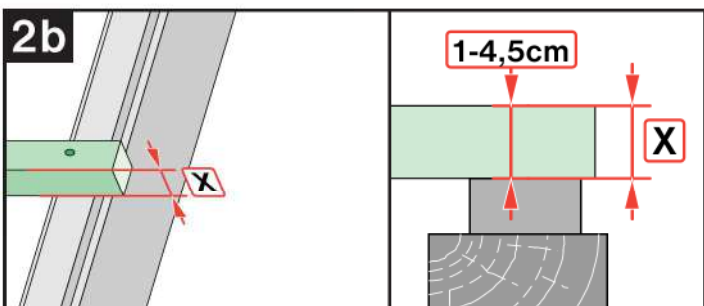

2c

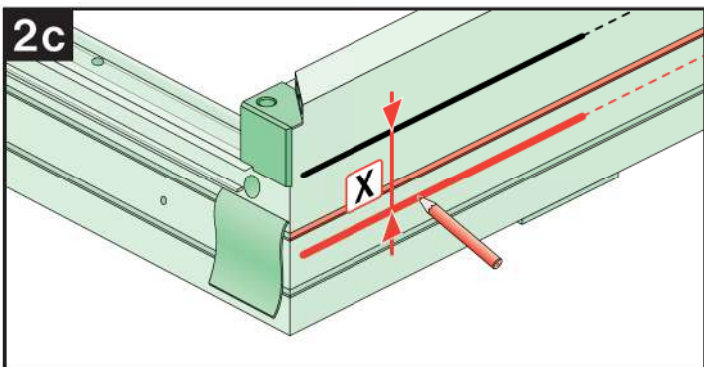

2d

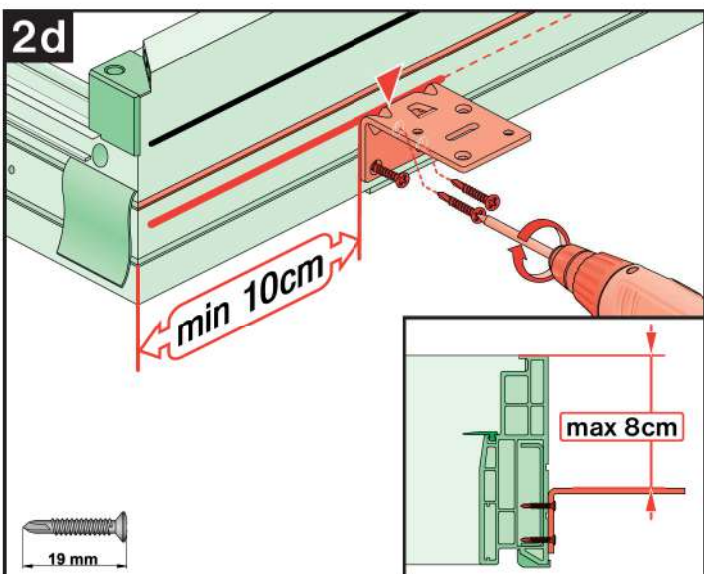

3a

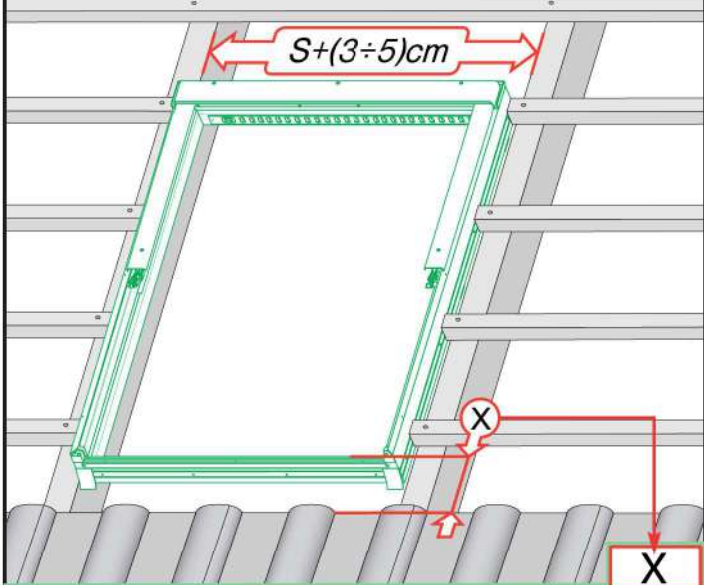
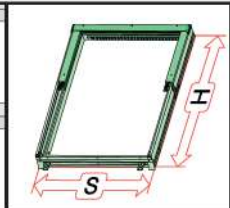

	EZJ	20cm
	ELJ	11cm
	EEJ	11cm

X

3b

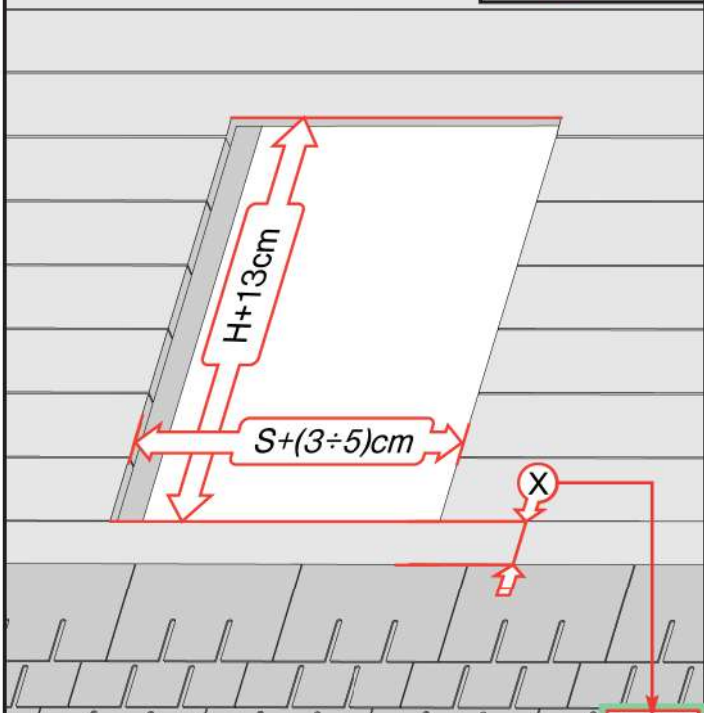
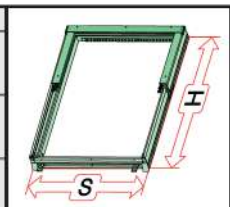

	ESJ	0cm
--	-----	-----

X

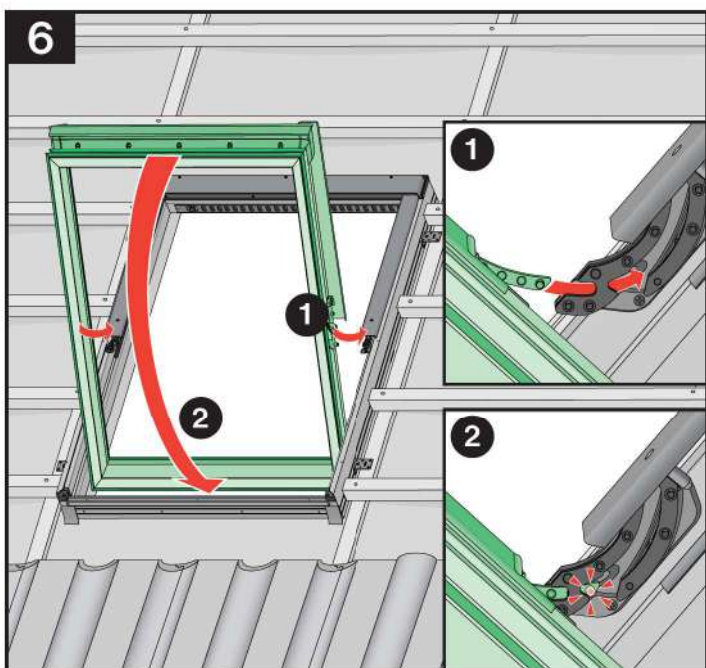
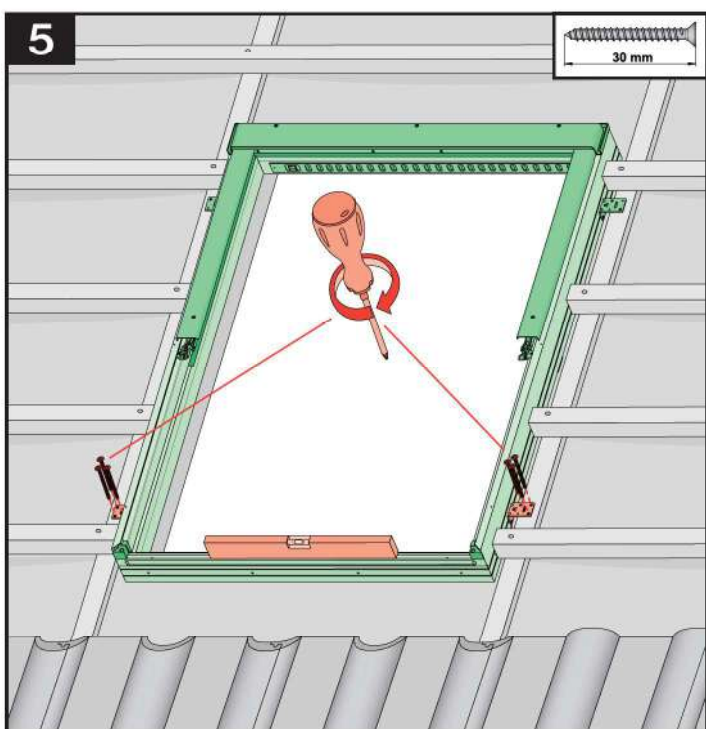
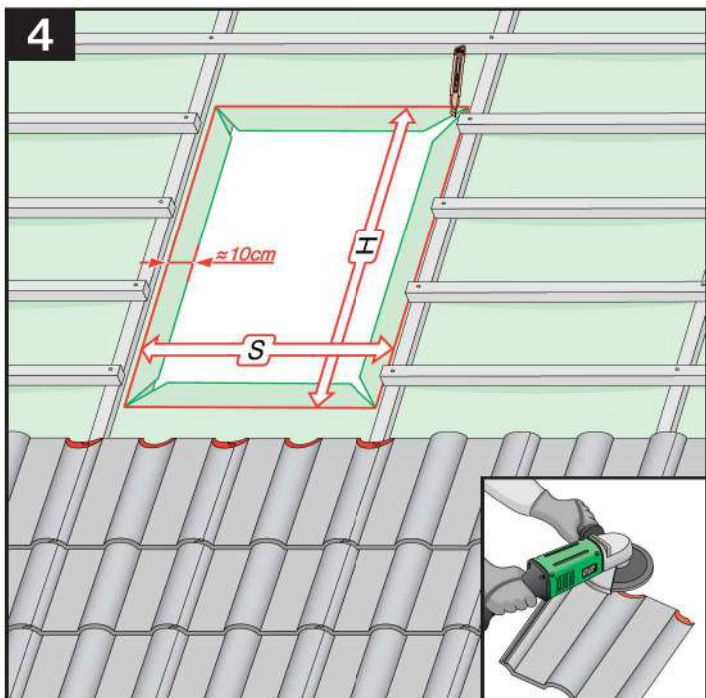

7

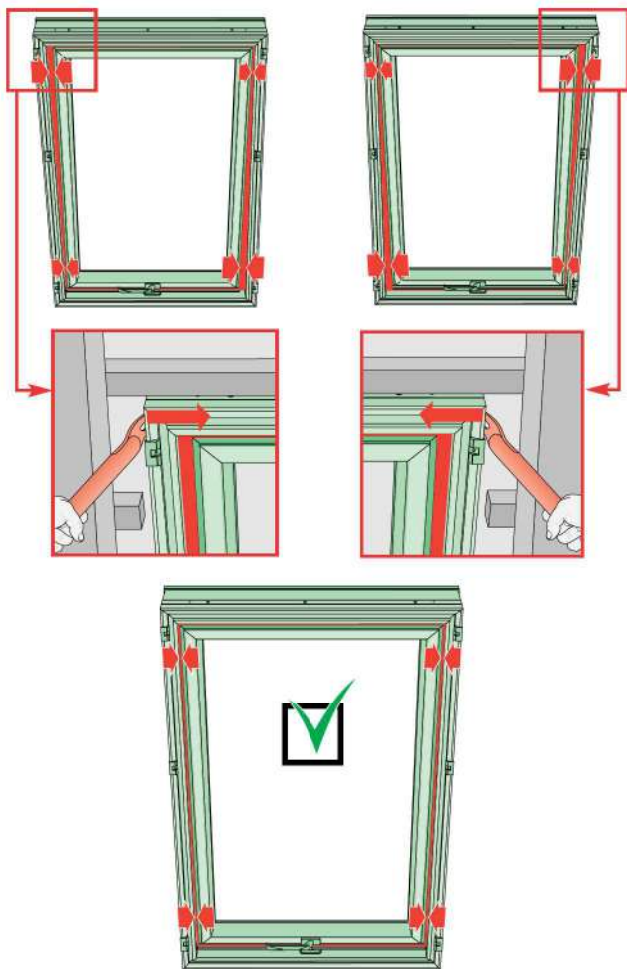

8

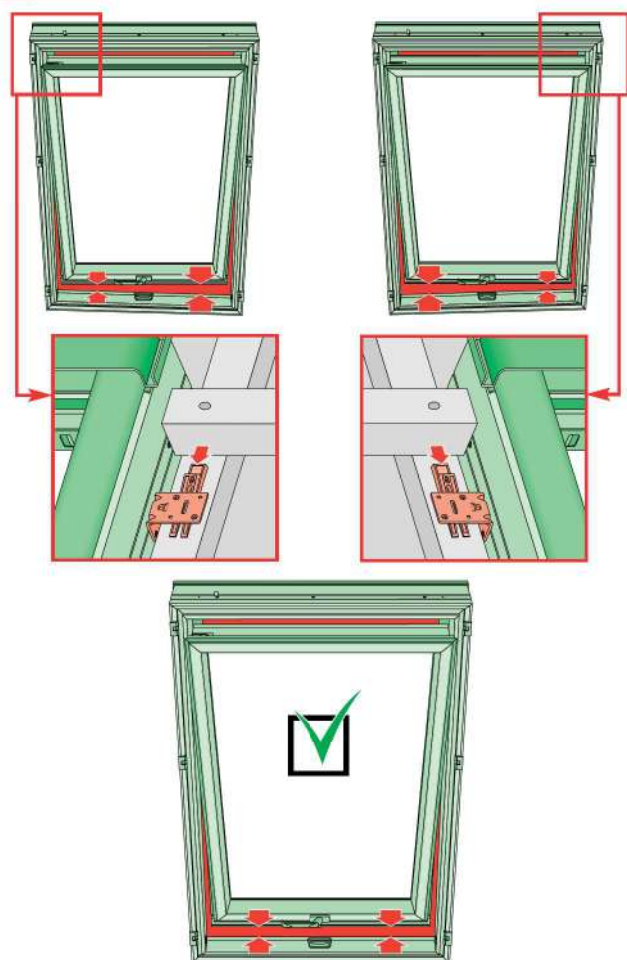

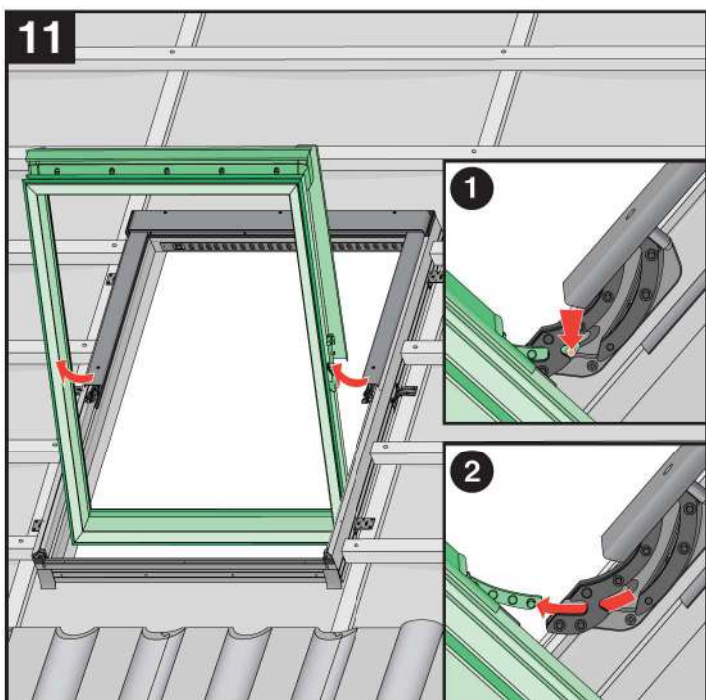
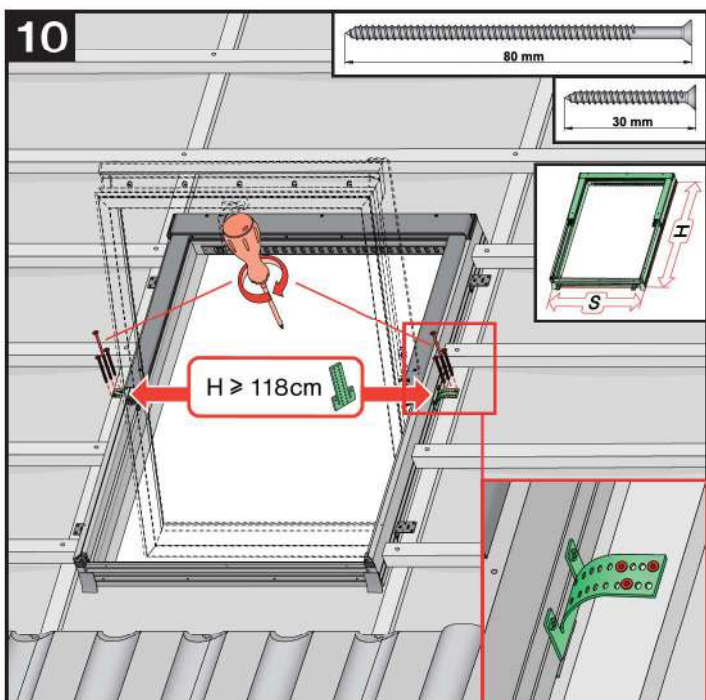
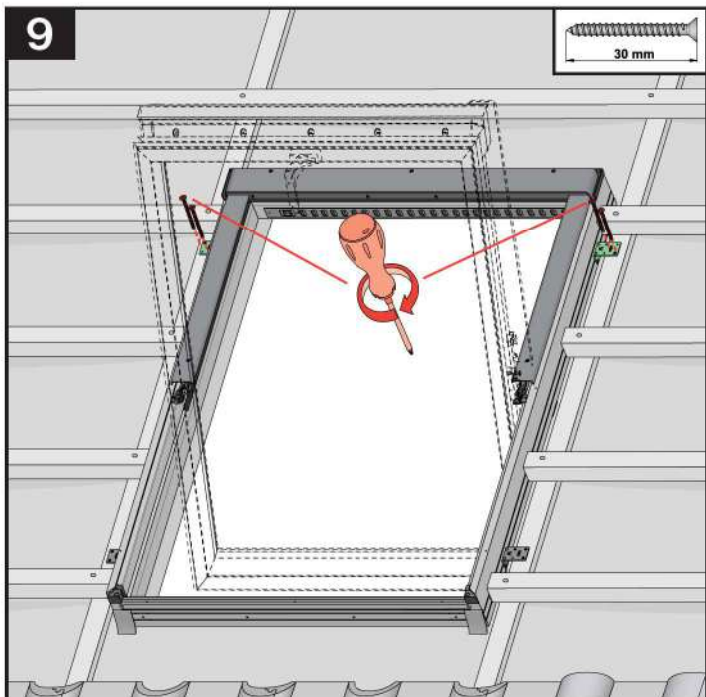

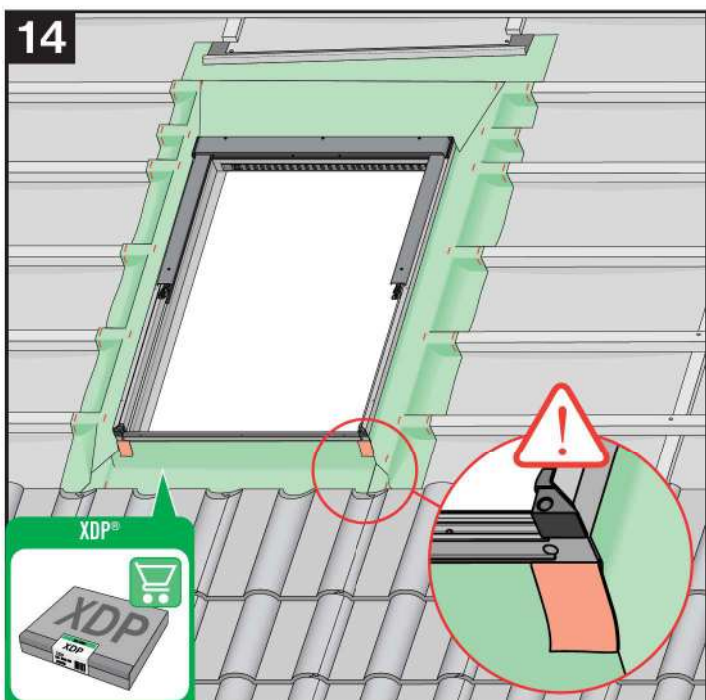
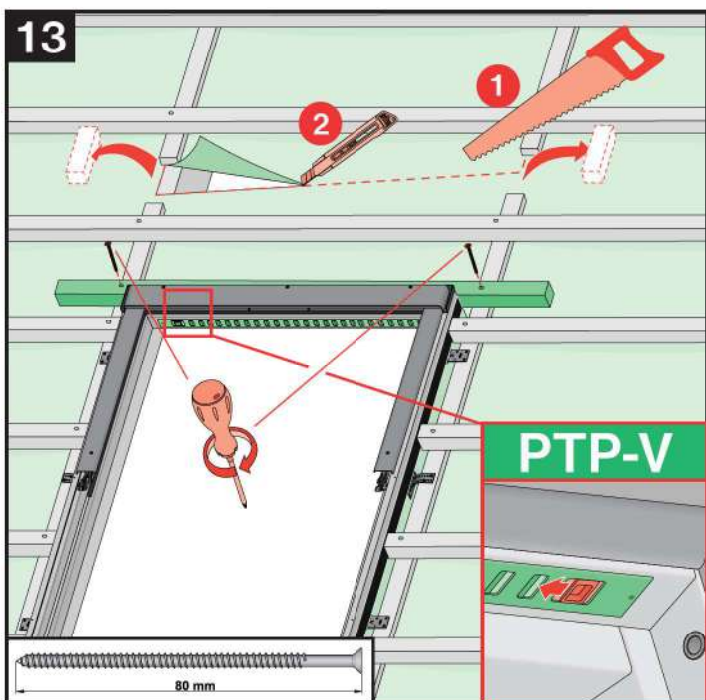
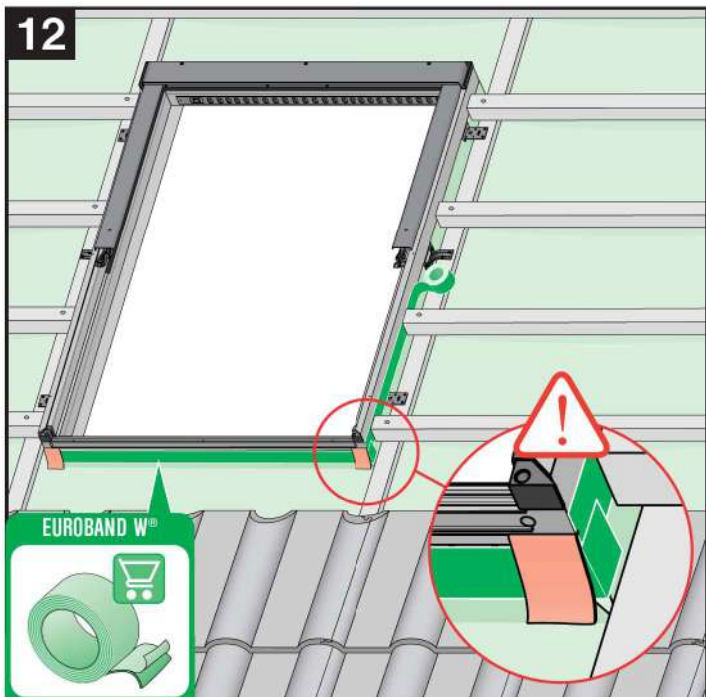

15

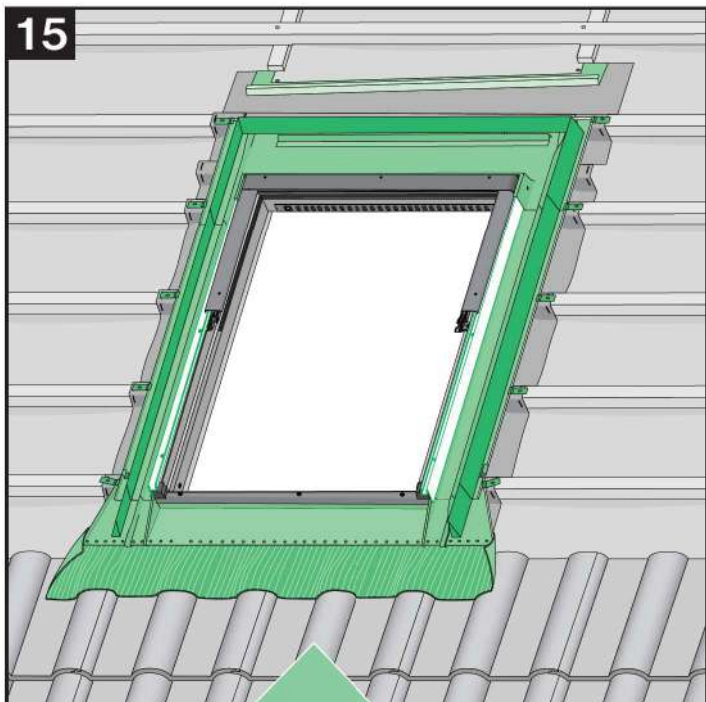

	max 45mm	EZJ
	max 5mm	ESJ
	max 5mm	ELJ
		EEJ

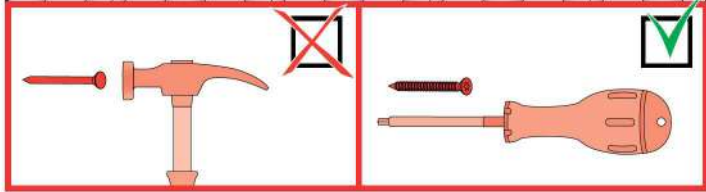
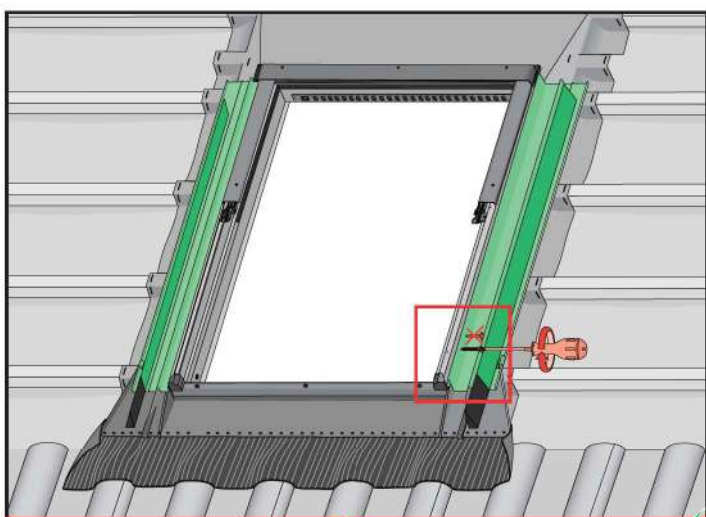
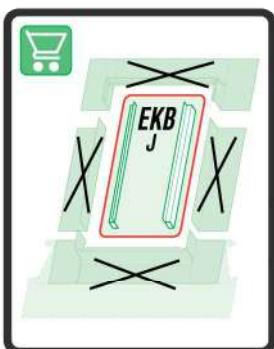

16



$a_1 = a_2$

$b_1 = b_2$

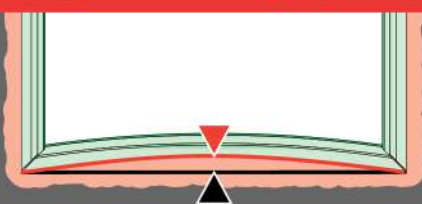
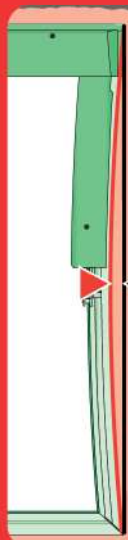
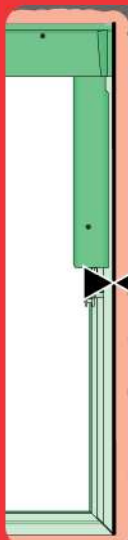
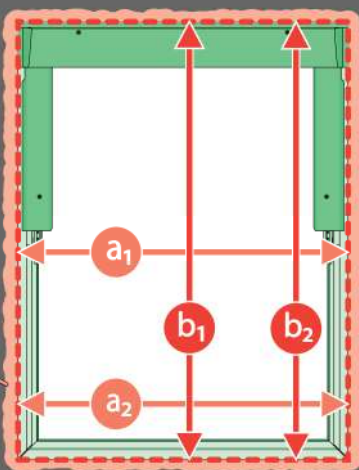

CZ	Výrobce a prodejce nesou žádnou odpovědnost za nedodržení příslušných ustanovení zákona, stavebních předpisů a bezpečnostních požadavků uživatelem výrobku, architektem, montérem nebo majitelem objektu.	NL	De fabrikant en verkoper zijn niet aansprakelijk voor gevolgen bij het niet opvolgen van toepasselijke wetten, bouwvoorschriften en veiligheidsvoorschriften door de gebruiker van het product, de architect, de installateur of de eigenaar van het gebouw.
DE	Hersteller und Verkäufer übernehmen keine Haftung für Nichtbeachtung entsprechender Rechts- und Bauvorschriften sowie Sicherheitsanforderungen seitens Produktbenutzers, Architekten, Monteurs oder Gebäudebesitzers.	PL	Producent i Sprzedawca nie ponosi żadnej odpowiedzialności za nieprzebranie stosownych przepisów prawa, przepisów budowlanych i wymogów bezpieczeństwa przez użytkownika produktu, architekta, montażystę lub właściciela budynku.
ES	El fabricante y el vendedor no tienen ninguna responsabilidad por el incumplimiento de la ley vigente, normas de construcción y exigencias de seguridad por parte del usuario del producto, arquitecto, instalador o el propietario del edificio.	PT	O fabricante e o vendedor não tem nenhuma responsabilidade pelo o não cumprimento da lei, códigos de construção e as exigências de segurança por parte do usuário do produto, arquiteto, instalador ou proprietário do edifício.
FR	Le fabricant et le revendeur ne prend aucune responsabilité de ne pas respecter les lois applicables, les règlements sur les bâtiments et les exigences de sécurité par l'utilisateur du produit, l'architecte, l'installateur ou le propriétaire du bâtiment.	RO	Nici producătorul, nici distribuitorul nu își vor asuma niciun fel de răspundere pentru nerespectarea legilor în vigoare, a legilor din domeniul construcțiilor sau a măsurilor de siguranță impuse utilizatorilor produsului, arhitecților, montajorilor sau proprietarilor clădirii.
GB	Manufacturer and Seller shall bear no liability for failure to comply with the applicable laws, building codes and safety requirements by the user of the product, architect, fitter or owner of the building.	RU	В случае несоблюдения архитектором, монтажником или владельцем здания строительных правил и норм безопасности ответственность с производителя и продавца снимается.
HU	A gyártó és a forgalmazó nem vállal semmilyen felelősséget a vonatkozó törvényi, építészeti és biztonsági előírások nemtörődömségéért, építész, beépítőmester vagy építésszervezők által be nem tartásáért.	SK	Výrobca a predajca nenesú žiadnu zodpovednosť za nedodržanie príslušných ustanovení zákona, stavebných predpisov a bezpečnostných požiadaviek užívateľom výrobku, architektom, montérom alebo majiteľom objektu.
IT	Il Produttore e il Rivenditore non potranno essere ritenuti responsabili per il mancato rispetto, da parte dell'utente del prodotto, del progettista, dell'installatore o del proprietario dell'edificio, delle leggi vigenti, nonché dei regolamenti edili e di quelli relativi alla sicurezza.		